

Fellowes

*Complete Table &
Worksurface Guide*

Table of Contents

- Table base overview*..... 5
- All-Flex® 2-leg*..... 6
- All-Flex 3-leg*..... 9
- Victory™LX 2-leg*..... 13
- VictoryLX 3-leg*..... 16
- Triumph™LX*..... 20
- Trada™ 2-Leg*..... 23
- Trada 3-Leg*..... 25
- Weight Adjustable Espree™* 30
- Q Crank*..... 33
- Worksurfaces overview*..... 37
- TFL quick ship worksurfaces*..... 39
- TFL standard worksurfaces*..... 39
- HPL standard worksurfaces*..... 40
- HPL premium worksurfaces* 41
- Laminate options*..... 42
- Motific™*..... 44
- Terms and Conditions*..... 46

Please visit fellowes.com for current list pricing on all products included in this ordering guide.

Table bases & complete tables

Table base overview

How to order:

Most tables have multiple part numbers to accommodate varying worksurface dimensions. Finishes come in three colors for most bases Silver (-SLV), Black (-BLK) or White (-WHT) Use the table base code with the three letter color code to complete your part number.

Part number breakdown:

1. Pick your table base size

| 2T-LX-C28-24-SLV |

2. Pick your table base finish

| 2T-LX-C28-24-SLV |

| 2T-LX-C28-24-SLV |

This product number represents:

TriumphLX

Silver finish

Accommodates worksurfaces 36" w x 24" d, 42" w x 24" d or 48" w x 24" d

General Information

Table bases

Table bases can be sold separately or in combination with a worksurface.

Warranty: Lifetime

Sizing

Fellowes table bases are made to exact dimensions.

Worksurface program

Multiple worksurface shapes and laminates are available. See pages 42-48 for worksurface details including laminate colors. TFL quick ship worksurfaces are shipped out in 48 hours, contact Customer Service for lead times for TFL standard and HPL standard/premium worksurfaces. Table bases and worksurfaces can be purchased independently or as a combination. Fellowes worksurfaces are made to exact dimensions. If nominal sizing is needed, please specify when ordering.

Lead times

The LT product marker indicates that the lead time may vary depending on quantities, orders and their availability. Please contact our Customer Service Department for on-hand inventory when placing orders for products marked with LT.

All-Flex[®] 2-leg



Product specs

- Electric height adjustment
- 265 lb. base lifting capacity
- 1.5"/sec adjustment speed
- One part number for all 2-leg sizes - 26.0" height adjustment range
- 23.3"-49.3" (low/high) (excluding worksurface)
- Three stage adjustable legs
- Provides adjustable cross channels, top supports, and feet making it one of the most adjustable table bases on the market
- C-leg
- Foot is adjustable to 22.0" or 28.0" (patented design)
- Leg columns fold out for quick assembly
- Adjustable width frame accommodates worksurfaces 36.0"-72.0" wide
- Adjustable depth top supports expand to accommodate worksurfaces 24.0"-36.0" deep
- Notched cross channel offers ample space for keyboard tray glide tracks

- 7'2" power cord
- Digital keypad with four memory settings
- Anti-collision safety feature
- Soft start and stop
- Crossbar includes guide markings to assist in setting width
- Integrated control unit shelf
- Integrated storage for foot extension plate when not in use
- Integrated cable management
- Steel construction
- Low standby power consumption
- Table base is UL962 listed
- Two motors
- ADA compliant
- Locking casters are available
- Meets or exceeds BIFMA x5.5 guidelines
- Complete tables available (base and top)
- Warranty: Lifetime



Available base finishes

- Silver -SLV
- Black -BLK
- White -WHT

Caster kit

Set of four caster wheels for table base
Increases height by 2.0"
Locking casters for security

Model # CASTERKIT-FLEX2

Table base model #	Worksurface shape	Worksurface dimension	Available worksurfaces			
			TFL standard	HPL standard	HPL premium	
			Quick ship	Standard ship	Standard ship	Standard ship
FLEX2-_-_-	 Rectangle	36"w x 24"d	-	•	•	•
		42"w x 24"d	-	•	•	•
		48"w x 24"d	•	•	•	•
		60"w x 24"d	-	•	•	•
		72"w x 24"d	-	•	•	•
		36"w x 30"d	-	•	•	•
		42"w x 30"d	-	•	•	•
		48"w x 30"d	-	•	•	•
		60"w x 30"d	•	•	•	•
		72"w x 30"d	-	•	•	•

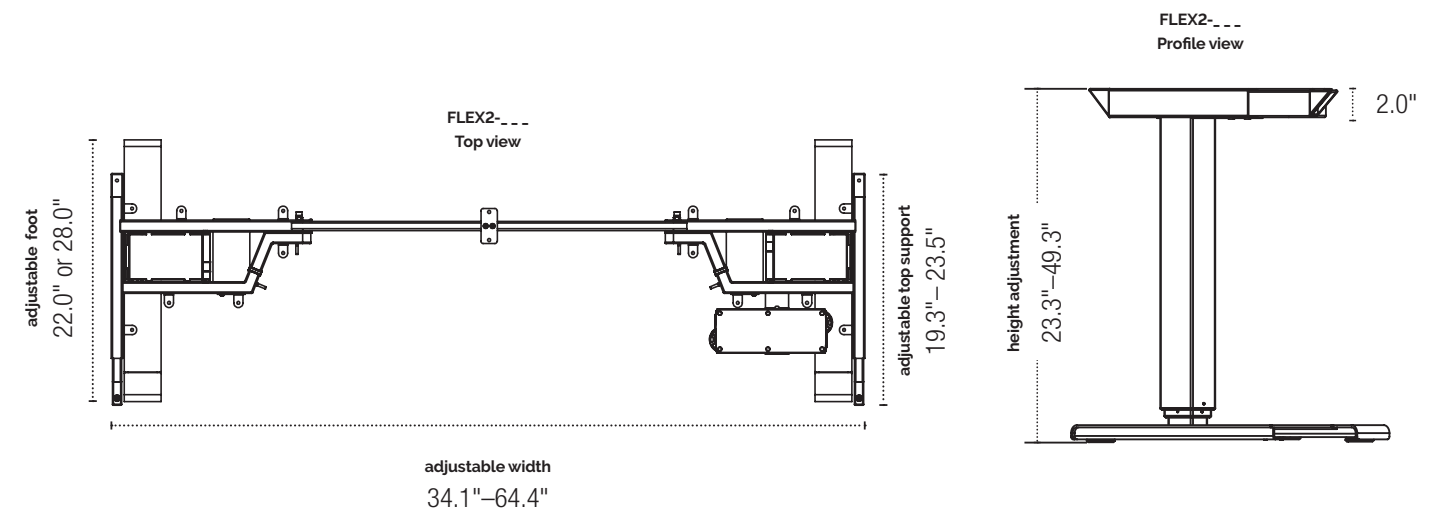

The base dimensions as shown are actual.

All-Flex® 2-leg complete table

Complete quick ship table model # breakdown:

2F_-R4824-QS-T_-
 | | | | | | | | |
 a b c d e f g h i

48.0" x 24.0" quick ship complete table

All-Flex 2-leg table base with a 48.0"w x 24.0"d rectangle TFL worksurface
 Model # 2F_-R4824-QS-T_-

60.0" x 30.0" quick ship complete table

All-Flex 2-leg table base with a 60.0"w x 30.0"d rectangle TFL worksurface
 Model # 2F_-R6030-QS-T_-

■ base finish notation ■ laminate color notation

All-Flex 2-leg table

Quick ship complete table options include: silver, black, or white table bases; 48.0"w x 24.0"d or 60.0"w x 30.0"d rectangle worksurfaces; all six TFL laminates. For all other combinations, please call our Customer Service Department for the estimated lead time and cost.

- a: number of legs
- b: type of table base
- c: finish of base
- d: worksurface shape
- e: worksurface width
- f: worksurface depth
- g: quick ship indicator
- h: laminate material
- i: laminate color

Available base finishes

Silver -S

Black -B

White -W

Available TFL quick ship laminates

Beigewood -BG

Phantom Charcoal -PC

Shadow Oak -SO

Designer White -DW

Grey -GR

Dove Grey -DV

All-Flex® 3-leg



Product specs

- Electric height adjustment
- 330 lb. base lifting capacity
- 1.5"/sec adjustment speed
- One part number for all 3-leg sizes
- 26.0" height adjustment range
- 23.3"–49.3" (low/high) (excluding worksurface)
- Three-stage adjustable legs
- C-leg
- Provides adjustable cross channels, top supports, and feet making it one of the most adjustable table bases on the market
- Foot is adjustable to 22.0" or 28.0" (patented design)
- Adjustable width frame accommodates worksurfaces 48.0"–84.0" wide
- Adjustable depth top supports expand to accommodate worksurfaces 24.0"–36.0" deep
- Notched cross channel offers ample space for keyboard tray glide tracks
- 7'2" power cord

Available base finishes

Silver -SLV Black -BLK White -WHT

- Digital keypad with four memory settings
- Anti-collision safety feature
- Soft start and stop
- Crossbar includes guide markings to assist in setting width
- Leg columns fold out for easy assembly
- Integrated control unit shelf
- Integrated storage for foot extension plate when not in use
- Integrated cable management
- Steel construction
- Low standby power consumption
- Table base is UL962 listed
- Three motors
- ADA compliant
- Locking casters are available
- Meets or exceeds BIFMA x5.5 guidelines
- Complete tables available (base and top)
- Warranty: Lifetime



Caster kit

Set of five caster wheels for table base
 Increases height by 2.0"
 Locking casters for security

Model # CASTERKIT-FLEX3

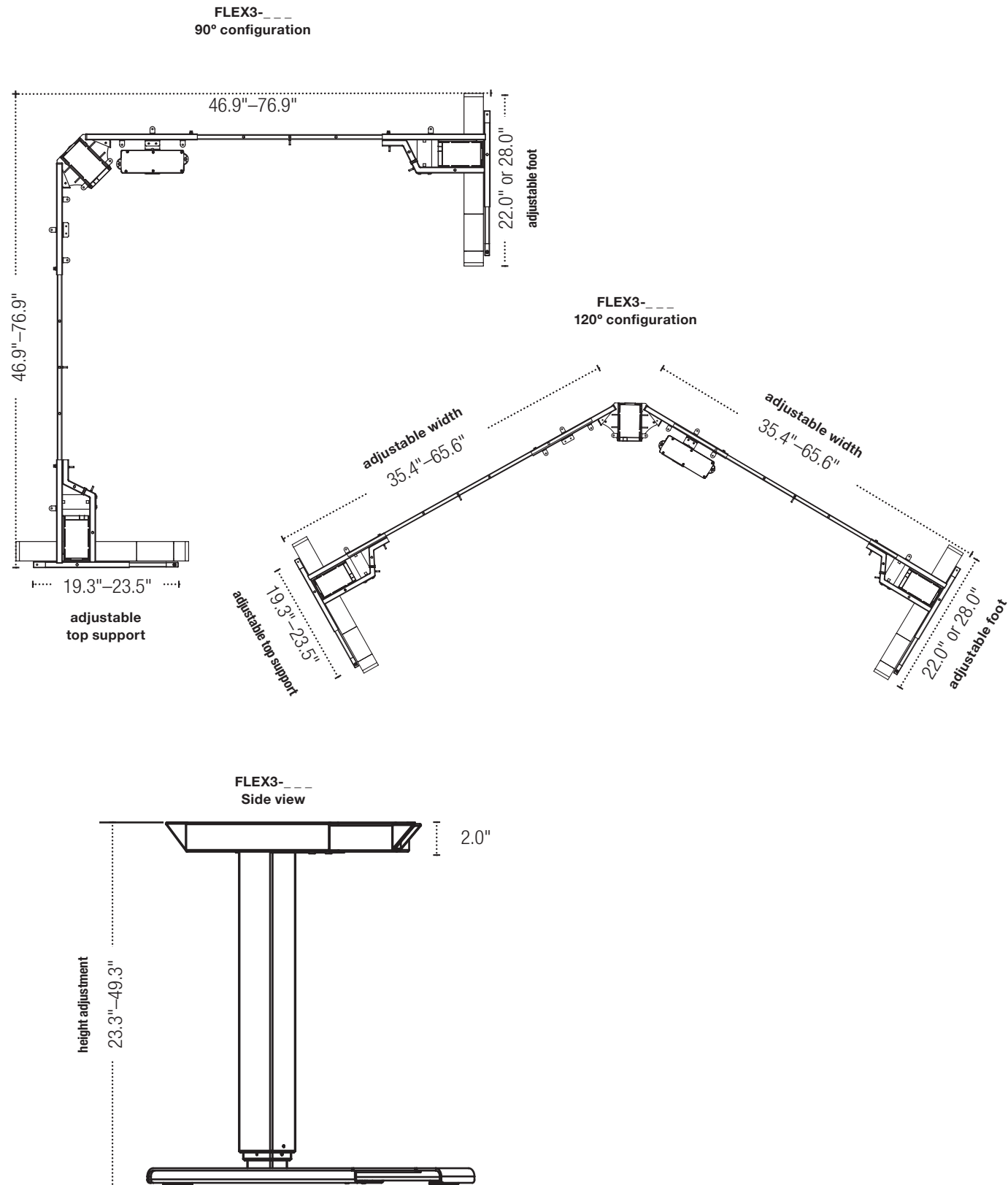

The base dimensions as shown are actual.

Table base model #	Worksurface shape	Worksurface dimension	Available worksurfaces			
			TFL standard	HPL standard	HPL premium	
			Quick ship	Standard ship	Standard ship	Standard ship
FLEX3- ___		60"wl x 60"wr x 24"d	-	•	•	•
		72"wl x 72"wr x 24"d	-	•	•	•
		60"wl x 60"wr x 30"d	-	•	•	•
		72"wl x 72"wr x 30"d	-	•	•	•
FLEX3- ___		48"w x 24"d	-	•	•	•
		60"w x 24"d	-	-	•	•
		72"w x 24"d	-	-	•	•
		48"w x 30"d	-	-	•	•
		60"w x 30"d	-	-	•	•
		72"w x 30"d	-	-	•	•
FLEX3- ___		60"wl x 48"wr x 24"d	-	•	•	•
		72"wl x 48"wr x 24"d	-	•	•	•
		72"wl x 60"wr x 24"d	-	•	•	•
		84"wl x 48"wr x 24"d	-	•	•	•
		84"wl x 60"wr x 24"d	-	-	•	•
		60"wl x 48"wr x 30"d	-	•	•	•
		72"wl x 48"wr x 30"d	-	•	•	•
		72"wl x 60"wr x 30"d	-	•	•	•
		84"wl x 48"wr x 30"d	-	-	•	•
		84"wl x 60"wr x 30"d	-	-	•	•
FLEX3- ___		48"wl x 60"wr x 24"d	-	•	•	•
		48"wl x 72"wr x 24"d	-	•	•	•
		60"wl x 72"wr x 24"d	-	•	•	•
		48"wl x 84"wr x 24"d	-	•	•	•
		60"wl x 84"wr x 24"d	-	-	•	•
		48"wl x 60"wr x 30"d	-	•	•	•
		48"wl x 72"wr x 30"d	-	•	•	•
		60"wl x 72"wr x 30"d	-	•	•	•
		48"wl x 84"wr x 30"d	-	-	•	•
60"wl x 84"wr x 30"d	-	-	•	•		

Victory™ LX 2-leg



Product specs

- Electric height adjustment
- 250 lb. base lifting capacity
- 1.4"/sec adjustment speed
- 26.0" height adjustment range - 21.5"–47.5" (low/high) (excluding worksurface)
- Three stage adjustable legs
- C-leg
- Frame and column connect and lock for quick and easy assembly
- Adjustable width frame accommodates worksurfaces 36.0"–72.0"
- Soft start and stop
- Gyro sensor anti-collision
- Locking casters available
- Two motors
- ADA compliant
- 8'9" power cord
- Table base is UL962 listed
- Meets or exceeds BIFMA x5.5, GI and CSA CAN/CGSB44.227
- Works with peds or storage with 18.5" max. height
- Low standby power consumption
- Steel frame and foot construction
- Digital keypad with three memory settings
- Keypad can slide under worksurface to store out of the way
- Complete tables available (base and top)
- Warranty: Lifetime

Available base finishes

- Silver -SLV
- Black -BLK
- White -WHT

Caster kit

Set of four caster wheels for table base
Increases height by 2.0"
Locking casters for security

Model # CASTERKIT-LX-2LEG

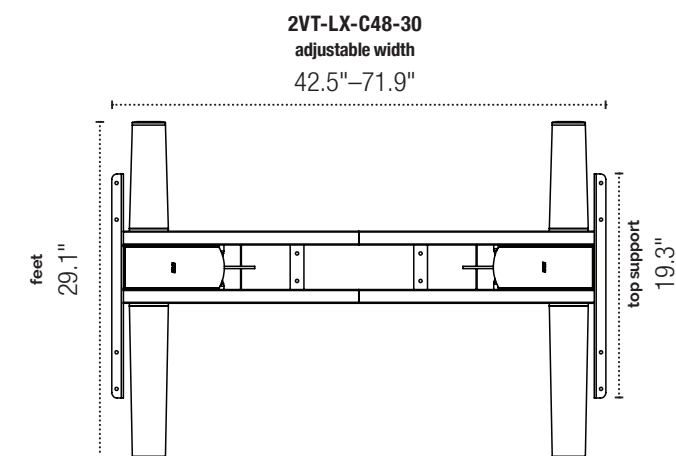
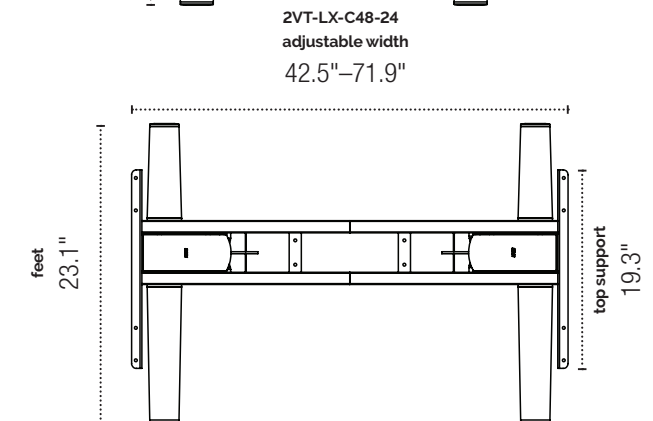
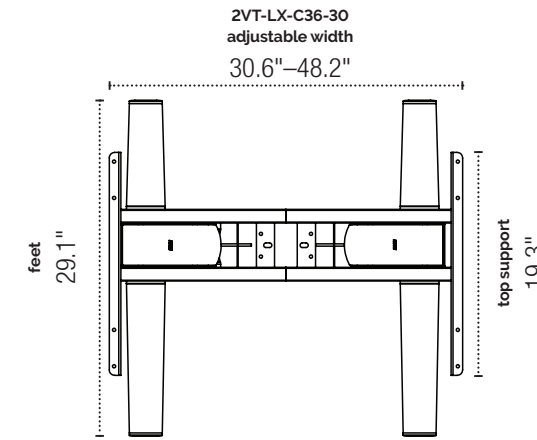
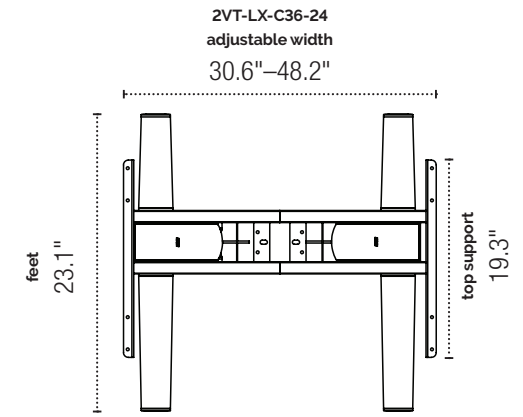

The base dimensions as shown are actual.

Table base model #	Worksurface shape	Worksurface dimension	Available worksurfaces			
			TFL standard		HPL standard	HPL premium
			Quick ship	Standard ship	Standard ship	Standard ship
2VT-LX-C36-24-___	Rectangle	36" w x 24" d	-	•	•	•
		42" w x 24" d	-	•	•	•
		48" w x 24" d	•	•	•	•
2VT-LX-C48-24-___	Rectangle	60" w x 24" d	-	•	•	•
		72" w x 24" d	-	•	•	•
		36" w x 30" d	-	•	•	•
2VT-LX-C36-30-___	Rectangle	42" w x 30" d	-	•	•	•
		48" w x 30" d	-	•	•	•
		60" w x 30" d	•	•	•	•
2VT-LX-C48-30-___	Rectangle	72" w x 30" d	-	•	•	•

Victory™ LX 2-leg complete table

Complete quick ship table model # breakdown:

2VT_-R4824-QS-T_-_-

a | b | c | d | e | f | g | h | i

- a: number of legs
- b: type of table base
- c: finish of base
- d: worksurface shape
- e: worksurface width
- f: worksurface depth
- g: quick ship indicator
- h: laminate material
- i: laminate color

48.0" x 24.0" quick ship complete table

VictoryLX 2-leg table base with a 48.0" w x 24.0" d rectangle TFL worksurface
 Model # 2VT_-R4824-QS-T_█

60.0" x 30.0" quick ship complete table

VictoryLX 2-leg table base with a 60.0" w x 30.0" d rectangle TFL worksurface
 Model # 2VT_-R6030-QS-T_█

█ base finish notation █ laminate color notation

Available base finishes

- Silver -S
- Black -B
- White -W

Available TFL quick ship laminates

- Beigewood -BG
- Phantom Charcoal -PC
- Shadow Oak -SO
- Designer White -DW
- Grey -GR
- Dove Grey -DV

VictoryLX 2-leg table

Quick ship complete table options include: silver, black, or white table bases; 48.0" w x 24.0" d or 60.0" w x 30.0" d rectangle worksurfaces; all six TFL laminates. Quick ship worksurfaces will be pre-drilled to accommodate the VictoryLX 2-leg table base. For all other combinations, please call our Customer Service Department for the estimated lead time and cost.

Victory™ LX 3-leg



Product specs

- Electric height adjustment
- 360 lb. base lifting capacity
- 1.4"/sec adjustment speed
- -26.0° height adjustment range
- 21.5"-47.5" (low/high) (excluding worksurface)
- Three stage adjustable legs
- C-leg
- Adjustable width frame accommodates worksurfaces 48.0"-84.0"
- Three motors
- Soft start and stop
- Anti-collision safety feature
- Locking casters available
- Low standby power consumption
- ADA compliant
- 8'9" power cord
- Table base is UL962 listed
- Meets or exceeds BIFMA x5.5, GI and CSA CAN/CGSB44.227
- Works with peds or storage with 20.0" max. height
- Steel frame and foot construction
- Digital keypad with three memory settings
- Keypad can slide under worksurface to store out of the way
- Complete tables available (base and top)
- Warranty: Lifetime

Available base finishes

- Silver -SLV
- Black -BLK
- White -WHT



Caster kit

- Set of six caster wheels for table base
- Includes third foot for caster installation
- Increases height by 2.0"
- Locking casters for security

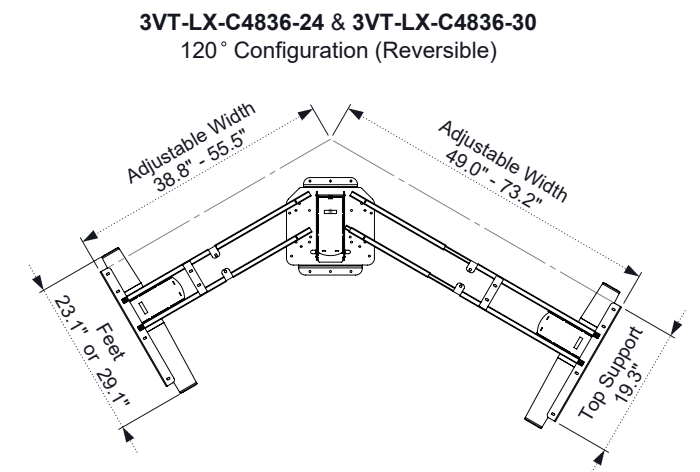
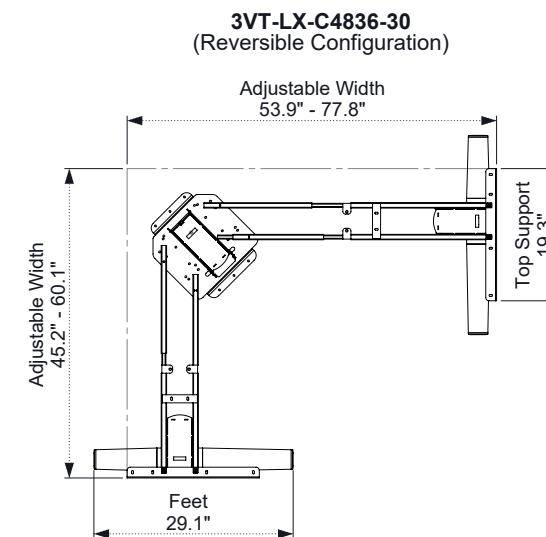
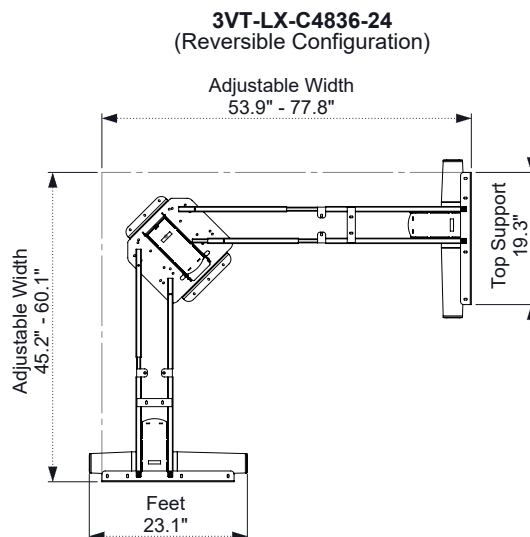
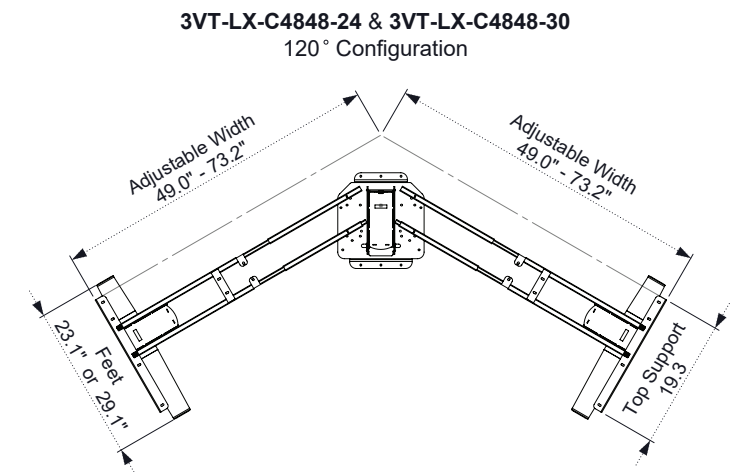
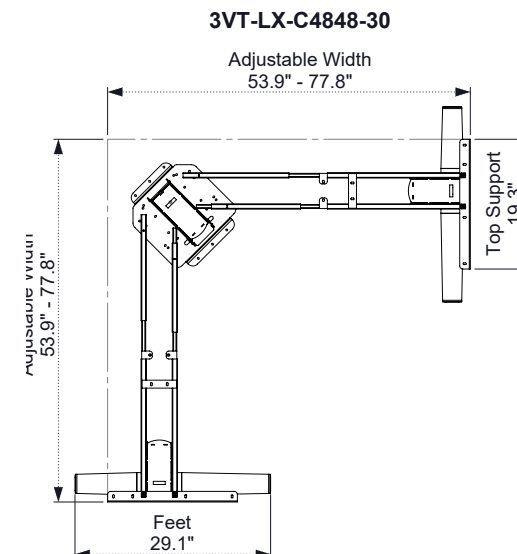
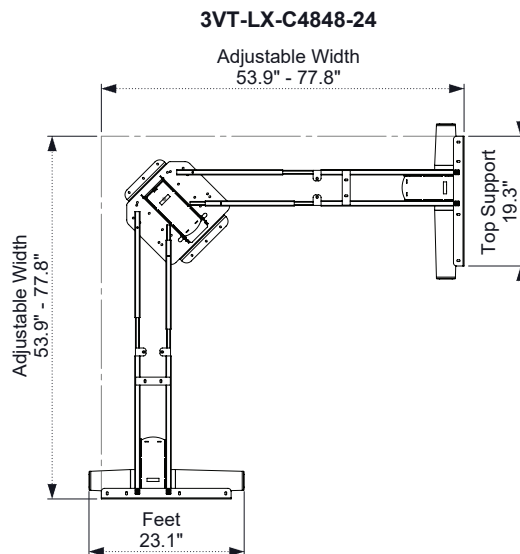
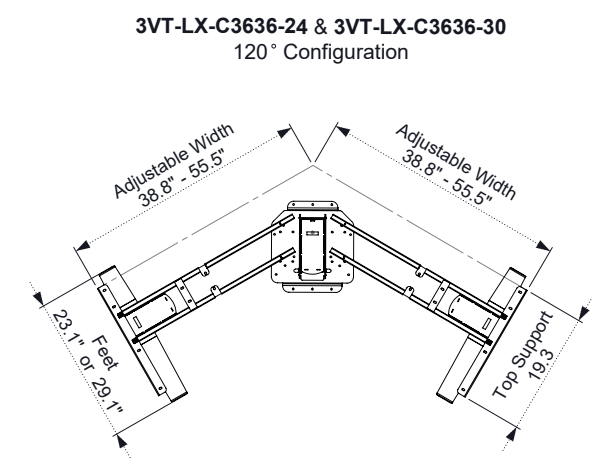
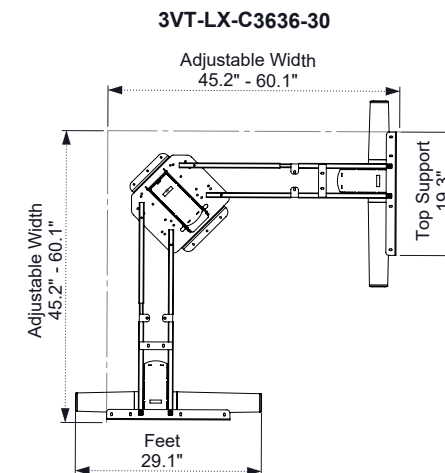
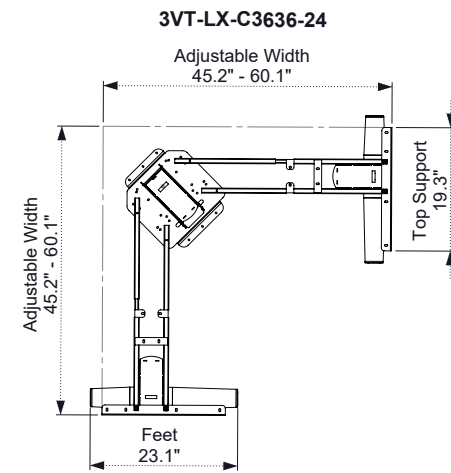
- Model # CASTERKIT-LX-3LEG-SLV
- Model # CASTERKIT-LX-3LEG-BLK
- Model # CASTERKIT-LX-3LEG-WHT

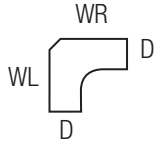
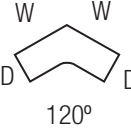
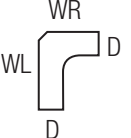

The base dimensions as shown are actual.

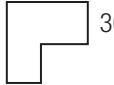
Table bases		Available worksurfaces					
Table base model #	Worksurface shape	Worksurface dimension	TFL standard		HPL standard	HPL premium	
			Quick ship	Standard ship	Standard ship	Standard ship	
3VT-LX-C4848-24-___		60"wl x 60"wr x 24"d	-	•	•	•	
		72"wl x 72"wr x 24"d	-	•	•	•	
3VT-LX-C4848-30-___	Equal corner	60"wl x 60"wr x 30"d	-	•	•	•	
		72"wl x 72"wr x 30"d	-	•	•	•	
3VT-LX-C3636-24-___		48"w x 24"d	-	•	•	•	
3VT-LX-C4848-24-___		60"w x 24"d	-	-	•	•	
3VT-LX-C3636-30-___		72"w x 24"d	-	-	•	•	
3VT-LX-C4848-30-___		48"w x 30"d	-	-	•	•	
		60"w x 30"d	-	-	•	•	
		72"w x 30"d	-	-	•	•	
3VT-LX-C4836-24-___		60"wl x 48"wr x 24"d	-	•	•	•	
		72"wl x 48"wr x 24"d	-	•	•	•	
72"wl x 60"wr x 24"d		-	•	•	•		
3VT-LX-C4848-24-___		84"wl x 48"wr x 24"d	-	•	•	•	
3VT-LX-C4836-30-___		84"wl x 60"wr x 24"d	-	-	•	•	
		60"wl x 48"wr x 30"d	-	•	•	•	
3VT-LX-C4836-30-___		Offset corner left	72"wl x 48"wr x 30"d	-	•	•	•
			72"wl x 60"wr x 30"d	-	•	•	•
3VT-LX-C4848-30-___			84"wl x 48"wr x 30"d	-	-	•	•
			84"wl x 60"wr x 30"d	-	-	•	•
3VT-LX-C4836-24-___			48"wl x 60"wr x 24"d	-	•	•	•
			48"wl x 72"wr x 24"d	-	•	•	•
60"wl x 72"wr x 24"d	-		•	•	•		
3VT-LX-C4848-24-___	48"wl x 84"wr x 24"d		-	•	•	•	
3VT-LX-C4836-30-___	60"wl x 84"wr x 24"d		-	-	•	•	
	48"wl x 60"wr x 30"d		-	•	•	•	
3VT-LX-C4836-30-___	Offset corner right		48"wl x 72"wr x 30"d	-	•	•	•
			48"wl x 84"wr x 30"d	-	•	•	•
3VT-LX-C4848-30-___			60"wl x 72"wr x 30"d	-	-	•	•
			60"wl x 84"wr x 30"d	-	-	•	•
3VT-LX-C3636-2430-___			30.0"/24.0"				
3VT-LX-C4848-2430-___			24.0"/30.0"				
3VT-LX-C4836-2430-___		Reversible configurations					

Please contact our Customer Service Department to specify the dimensions and laminates for this style of worksurface



Product shown: Evolve2-FMS, Evolve3-FMS, Centro, VictoryLX 3-leg, Designer White worksurfaces, Railway, FlexCharge4, Solution 6

Triumph™ LX 2-leg



Product specs

- Electric height adjustment
- 250 lb. base lifting capacity
- 1.4"/sec. adjustment speed
- 17.0" height adjustment range
- 26.5"–43.5" (low/high) (excluding worksurface)
- Two stage adjustable legs
- C-leg
- Frame and column connect and lock for quick and easy assembly
- Adjustable width frame accommodates worksurfaces 36.0"–72.0"
- Two motors
- Digital keypad with three memory settings
- Soft start and stop
- Gyro sensor anti-collision
- Locking casters are available
- ADA compliant
- 8'9" power cord
- Steel frame and foot construction
- Works with peds or storage with 23.5" max. height
- Low standby power consumption
- Meets or exceeds BIFMA x5.5 guidelines
- Keypad can slide under worksurface to store out of the way
- Complete tables available (base and top)
- Warranty: Lifetime

Available base finishes

- Silver -SLV
- Black -BLK
- White -WHT

Caster kit

- Set of four caster wheels for table base
- Increases height by 2.0"
- Locking casters for security

Model # CASTERKIT-LX-2LEG

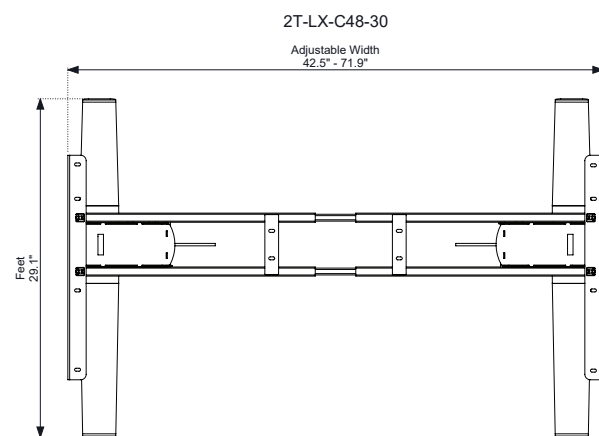
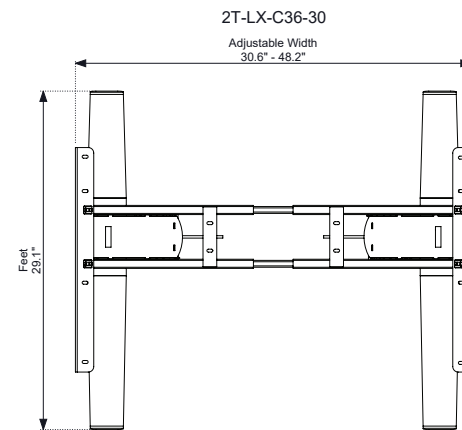
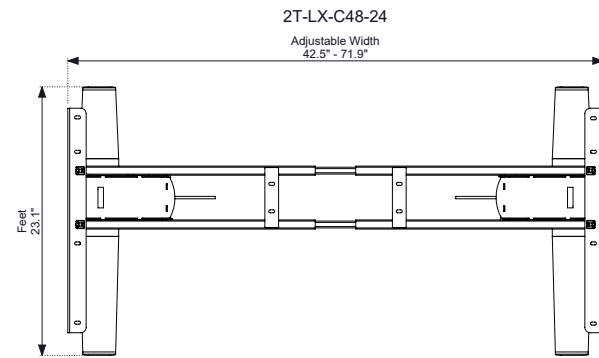
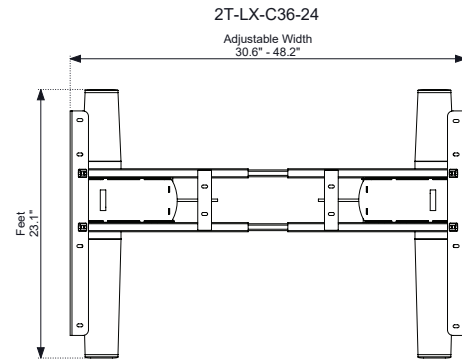

Table base model #	Worksurface shape	Worksurface dimension	Available worksurfaces			
			TFL standard		HPL standard	HPL premium
			Quick ship	Standard ship	Standard ship	Standard ship
2T-LX-C36-24-___	Rectangle	36"w x 24"d	–	•	•	•
		42"w x 24"d	–	•	•	•
		48"w x 24"d	•	•	•	•
2T-LX-C48-24-___	Rectangle	60"w x 24"d	–	•	•	•
		72"w x 24"d	–	•	•	•
2T-LX-C36-30-___	Rectangle	36"w x 30"d	–	•	•	•
		42"w x 30"d	–	•	•	•
		48"w x 30"d	–	•	•	•
2T-LX-C48-30-___	Rectangle	60"w x 30"d	•	•	•	•
		72"w x 30"d	–	•	•	•

Trada™ complete table

Complete quick ship table model # breakdown:

2TD_-R4824-QS-T_ _
 | | | | | | | | | |
 a b d e f g h i j

2TDM_-R4824-QS-T_ _
 | | | | | | | | | |
 a b c d e f g h i j

48.0" x 24.0" quick ship complete table

Trada table base with a 48.0" w x 24.0" d rectangle TFL worksurface with standard keypad
 MODEL # 2TD_-R4824-QS-T_ _

Trada table base with a 48.0" w x 24.0" d rectangle TFL worksurface with digital keypad
 MODEL # 2TDM_-R4824-QS-T_ _

60.0" x 30.0" quick ship complete table

Trada table base with a 60.0" w x 30.0" d rectangle TFL worksurface with standard keypad
 MODEL # 2TD_-R6030-QS-T_ _

Trada table base with a 60.0" w x 30.0" d rectangle TFL worksurface with digital keypad
 MODEL # 2TDM_-R6030-QS-T_ _

■ base finish notation ■ laminate color notation

Trada table

Quick ship complete table options include: silver, black, or white table bases; 48.0" w x 24.0" d or 60.0" w x 30.0" d rectangle worksurfaces; standard or digital keypad; all six TFL laminates. For all other combinations, please call our Customer Service Department for the estimated lead time and cost.

- a: number of legs
- b: type of table base
- c: 4-memory digital keypad
- d: finish of base
- e: worksurface shape
- f: worksurface width
- g: worksurface depth
- h: quick ship indicator
- i: laminate material
- j: laminate color

Available base finishes

- Silver -S
- Black -B
- White -W

Available TFL quick ship laminates

- Beigewood - BG
- Phantom Charcoal -PC
- Shadow Oak -SO
- Designer White -DW
- Grey -GR
- Dove Grey -DV



Product shown: Weight Adjustable Espree, Edge2-MS, Solution All-Fit, Lustre, FlexCharge4, CPU05

Triumph™ LX complete table

Complete quick ship table model # breakdown:

2T_-R4824-QS-T_-_-
 a b c d e f g h i

48.0" x 24.0" quick ship complete table

TriumphLX 2-leg table base with a 48.0" w x 24.0" d rectangle TFL worksurface
 Model # 2T_-R4824-QS-T_-_-

60.0" x 30.0" quick ship complete table

TriumphLX 2-leg table base with a 60.0" w x 30.0" d rectangle TFL worksurface
 Model # 2T_-R6030-QS-T_-_-

■ base finish notation ■ laminate color notation

TriumphLX table

Quick ship complete table options include: silver, black, or white table bases; 48.0" w x 24.0" d or 60.0" w x 30.0" d rectangle worksurfaces; all six TFL laminates. Quick ship worksurfaces will be pre-drilled to accommodate the TriumphLX table base. For all other combinations, please call our Customer Service Department for the estimated lead time and cost.

- a: number of legs
- b: type of table base
- c: finish of base
- d: worksurface shape
- e: worksurface width
- f: worksurface depth
- g: quick ship indicator
- h: laminate material
- i: laminate color

Available base finishes

- Silver -S
- Black -B
- White -W

Available TFL quick ship laminates

- Beigewood - BG
- Phantom Charcoal -PC
- Shadow Oak -SO
- Designer White -DW
- Grey -GR
- Dove Grey -DV

Trada™ 2 Leg



Product specs

- Electric height adjustment
- 265 lbs. base lifting capacity
- 1.5"/sec adjustment speed
- 25.5" height adjustment range - 24.5"–50.0" (low/high) (excluding worksurface)
- Anti-collision
- Three stage adjustable legs
- C-leg
- Adjustable width frame accommodates worksurfaces 48.0"–72.0"
- Soft start and stop
- Locking casters available
- Two motors
- ADA compliant
- g' power cord
- Table base is UL962 listed
- Meets or exceeds BIFMA x5.5, and CSA C22.2 #68 guidelines
- Works with peds or storage with 21.5" max. height
- Low standby power consumption
- Steel frame and foot construction
- Standard keypad with up and down buttons or digital 4-memory keypad available
- Complete tables available (base and top)
- Warranty: Lifetime

Available base finishes

- Silver -SLV
- Black -BLK
- White -WHT

Caster kit

Set of four caster wheels for table base
 Increases height by 2.0"
 Locking casters for security

Model # CASTERKIT-2TD

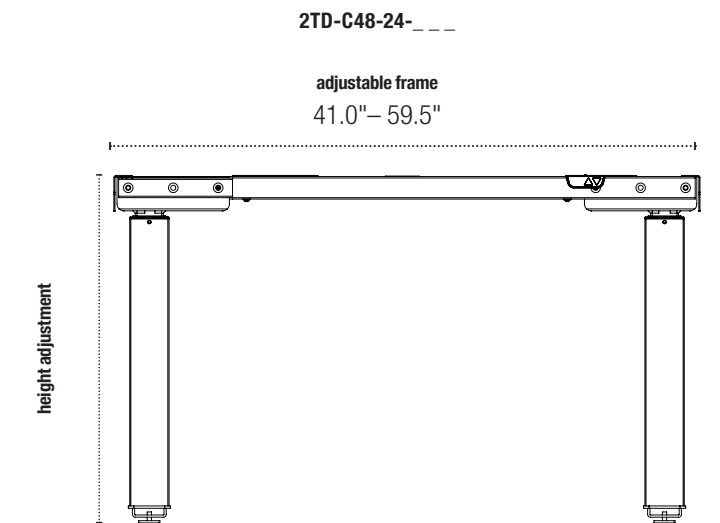
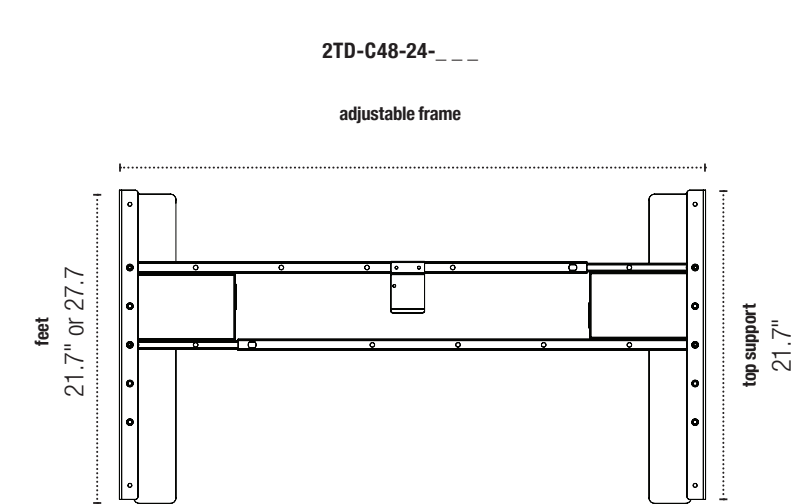

Digital 4 memory keypad

Digital Programmable Keypad with 4 memory settings
 Includes up and down buttons, a digital read out, 4 memory presets and a programmable upper and lower limit
 Sleep Mode to decrease power consumption

Model # 2TDM-DGTLKPD

The base dimensions as shown are actual.

Table bases		Available worksurfaces				
Table base model #	Worksurface shape	Worksurface dimension	TFL standard		HPL standard	HPL premium
			Quick ship	Standard ship	Standard ship	Standard ship
Model # with 2TD includes standard keypad Model # with 2TDM includes digital keypad		48"w x 24"d	•	•	•	•
2TD-C48-24-____ 2TDM-C48-24-____	 Rectangle	60"w x 24"d	-	•	•	•
		72"w x 24"d	-	•	•	•
		48"w x 30"d	-	•	•	•
2TD-C48-30-____ 2TDM-C48-30-____		60"w x 30"d	•	•	•	•
		72"w x 30"d	-	•	•	•

Trada™ 3-Leg



Product specs

- Electric height adjustment
- 397lb. base lifting capacity
- 1.5"/sec adjustment speed
- 25.5" height adjustment range - 24.5"-50.0" (low/high) *(excluding worksurface)*
- Anti-collision safety feature
- Three stage adjustable legs
- C-leg
- Adjustable width frame accommodates worksurfaces 48.0"-72.0"
- Soft start and stop
- Locking casters available
- Three motors
- ADA compliant
- 9' power cord
- Table base is UL962 listed
- Meets or exceeds BIFMA x5.5, and CSA C22.2 #68 guidelines
- Works with peds or storage with 22.0" max. height
- Low standby power consumption
- Steel frame and foot construction
- Standard keypad with up and down buttons or digital 4-memory keypad available
- Complete tables available *(base and top)*
- Warranty: Lifetime

Available base finishes

- Silver -SLV
 Black -BLK
 White -WHT

Caster Kit

Set of casters for table base
Increases height by 2.0"
Locking casters for security

Model # CASTERKIT-3TD

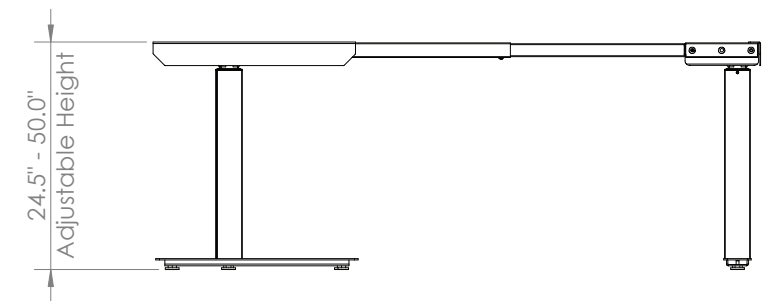
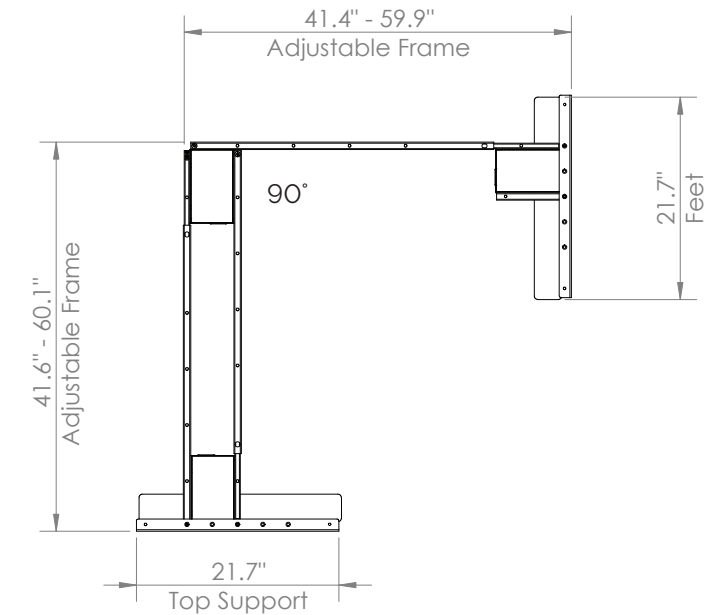

Digital 4 memory keypad

Digital Programmable Keypad with 4 memory settings
Includes up and down buttons, a digital read out, 4 memory presets and a programmable upper and lower limit
Sleep Mode to decrease power consumption

The base dimensions as shown are actual.

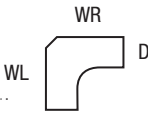
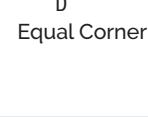
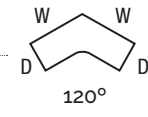
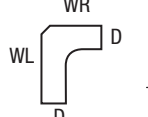
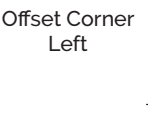
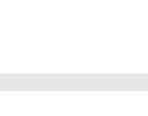

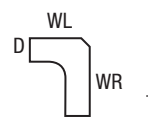
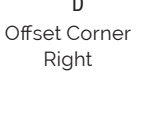

Table base model	Worksurface shape	Worksurface dimension	Available worksurfaces			
			Quick ship	TFL standard	HPL standard	HPL premium
				Standard ship	Standard ship	Standard ship
3TD-C4848-24-___ 3TDM-C4848-24-___		60"wl x 60"wr x 24"d	-	3EC606024-TFL-__	3EC606024-HPL-__	3EC606024-PHPL-__
72"wl x 72"wr x 24"d		-	3EC727224-TFL-__*	3EC727224-HPL-__*	3EC727224-PHPL-__*	
3TD-C4848-30-___ 3TDM-C4848-30-___	Equal Corner 	60"wl x 60"wr x 30"d	-	3EC606024-TFL-__*	3EC606030-HPL-__*	3EC606030-PHPL-__*
72"wl x 72"wr x 30"d		-	3EC727230-TFL-__	3EC727230-HPL-__	3EC727230-PHPL-__	
3TD-C4848-24-___ 3TDM-C4848-24-___		48"w x 24"d	-	120-4824-TFL-__	120-4824-HPL-__	120-4824-PHPL-__
3TD-C4848-24-___ 3TDM-C4848-24-___		60"w x 24"d	-	-	120-6024-HPL-__	120-6024-PHPL-__
3TD-C4848-24-___ 3TDM-C4848-24-___		72"w x 24"d	-	-	120-7224-HPL-__	120-7224-PHPL-__
3TD-C4848-30-___ 3TDM-C4848-30-___		48"w x 30"d	-	-	120-4830-HPL-__	120-4830-PHPL-__
3TD-C4848-30-___ 3TDM-C4848-30-___		60"w x 30"d	-	-	120-6030-HPL-__	120-6030-PHPL-__
3TD-C4848-30-___ 3TDM-C4848-30-___		72"w x 30"d	-	-	120-7230-HPL-__*	120-7230-PHPL-__*

Table base model	Worksurface shape	Worksurface dimension	Available worksurfaces			
			Quick ship	TFL standard	HPL standard	HPL premium
				Standard ship	Standard ship	Standard ship
3TD-C4848-24-___ 3TDM-C4848-24-___		60"wr x 48"wl x 24"d	-	3OCL604824-TFL-__	3OCL604824-HPL-__	3OCL604824-PHPL-__
72"wl x 48"wr x 24"d		-	3OCL724824-TFL-__	3OCL724824-HPL-__	3OCL724824-PHPL-__	
72"wl x 60"wr x 24"d		-	3OCL726024-TFL-__	3OCL726024-HPL-__	3OCL726024-PHPL-__	
3TD-C4848-24-___ 3TDM-C4848-24-___	Offset Corner Left 	84"wl x 48"wr x 24"d	-	3OCL844824-TFL-__	3OCL844824-HPL-__	3OCL844824-PHPL-__
84"wl x 60"wr x 24"d		-	-	3OCL846024-HPL-__	3OCL846024-PHPL-__	
60"wl x 48"wr x 30"d		-	3OCL604830-TFL-__	3OCL604830-HPL-__	3OCL604830-PHPL-__	
3TD-C4848-30-___ 3TDM-C4848-30-___	Offset Corner Left 	72"wl x 48"wr x 30"d	-	3OCL724830-TFL-__	3OCL724830-HPL-__	3OCL724830-PHPL-__
72"wl x 60"wr x 30"d		-	3OCL726030-TFL-__	3OCL726030-HPL-__	3OCL726030-PHPL-__	
84"wl x 48"wr x 30"d		-	-	3OCL844830-HPL-__	3OCL844830-PHPL-__	
3TD-C4848-30-___ 3TDM-C4848-30-___	Offset Corner Left 	84"wl x 60"wr x 30"d	-	-	3OCL846030-HPL-__	3OCL846030-PHPL-__
48"wl x 60"wr x 24"d		-	3OCR486024-TFL-__	3OCR486024-HPL-__	3OCR486024-PHPL-__	
48"wl x 72"wr x 24"d		-	3OCR487224-TFL-__	3OCR487224-HPL-__	3OCR487224-PHPL-__	
3TD-C4848-24-___ 3TDM-C4848-24-___	Offset Corner Right 	60"wl x 72"wr x 24"d	-	3OCR607224-TFL-__	3OCR607224-HPL-__	3OCR607224-PHPL-__
48"wl x 84"wr x 24"d		-	3OCR488424-TFL-__	3OCR488424-HPL-__	3OCR488424-PHPL-__	
60"wl x 84"wr x 24"d		-	-	3OCR608424-HPL-__	3OCR608424-PHPL-__	
3TD-C4848-30-___ 3TDM-C4848-30-___	Offset Corner Right 	48"wl x 60"wr x 30"d	-	3OCR486030-TFL-__	3OCR486030-HPL-__	3OCR486030-PHPL-__
48"wl x 72"wr x 30"d		-	3OCR487230-TFL-__	3OCR487230-HPL-__	3OCR487230-PHPL-__	
48"wl x 84"wr x 30"d		-	3OCR607230-TFL-__	3OCR607230-HPL-__	3OCR607230-PHPL-__	
3TD-C4848-30-___ 3TDM-C4848-30-___	Offset Corner Right 	60"wl x 72"wr x 30"d	-	-	3OCR488430-HPL-__	3OCR488430-PHPL-__
60"wl x 84"wr x 30"d		-	-	3OCR608430-HPL-__	3OCR608430-PHPL-__	

Weight Adjustable Espree™



Product specs

- Pneumatic height adjustment
- 19.5" height adjustment range - 26.3"–45.8" (low/high) *(excluding worksurface)*
- 44–143 lb. base lifting capacity *(2ESP-WA-C48)*
- 52–163 lb. base lifting capacity *(2ESP-WA-C60)*
- Three stage adjustable legs
- C-leg
- Foot is adjustable to 22.0" or 28.0" *(patented design)*
- Fixed width frame
- Table bases accommodate worksurfaces measuring 48.0" and 60.0" in width
- Weight adjustable with adjustment gauge
- Includes adjustment tools
- Locking casters are available
- The user has the ability to change the weight resistance in the base for easy height adjustment
- Counter-balanced columns provide smooth, synchronized height adjustment
- Weight adjustment cylinder includes preventative hard stop
- Complete tables available *(base and top)*
- Warranty: Lifetime



Available base finishes

- Silver -SLV
- Black -BLK
- White -WHT

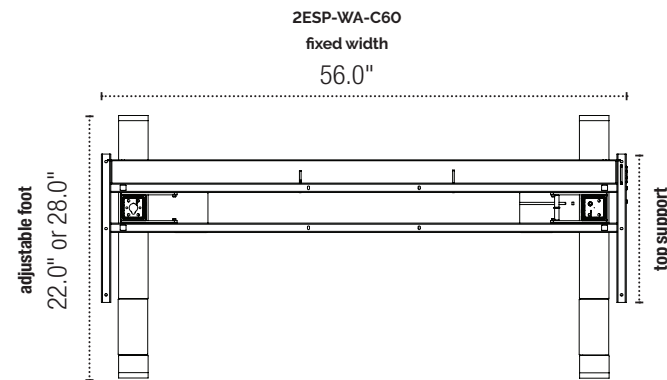
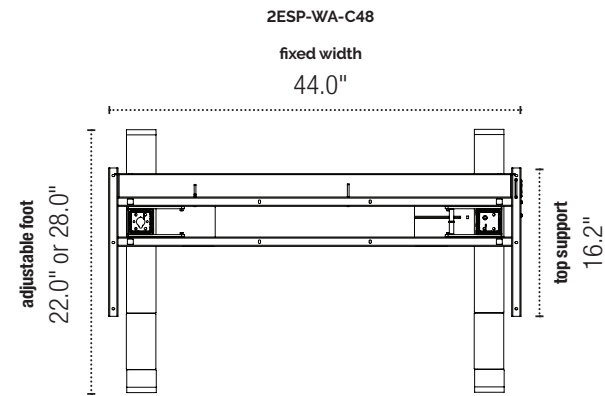

The base dimensions as shown are actual.

Caster kit

Set of four caster wheels for table base
Increases height by 2.0"
Locking casters for security

Model # CASTERKIT-ESP-WA

Table bases	Worksurface shape	Worksurface dimension	Available worksurfaces			
			TFL standard	HPL standard	HPL premium	
Table base model #			Quick ship	Standard ship	Standard ship	Standard ship
2ESP-WA-C48- ___	 Rectangle	48"w x 24"d	•	•	•	•
		48"w x 30"d	–	•	•	•
2ESP-WA-C60- ___		60"w x 24"d	–	•	•	•
		60"w x 30"d	•	•	•	•

Weight Adjustable Espree™ complete table

Complete quick ship table model # breakdown:

2ESPWA_-R4824-QS-T_-_-
 a b c d e f g h i

48.0" x 24.0" quick ship complete table

Weight Adjustable Espree 2-leg table base with a 48.0"w x 24.0"d rectangle TFL worksurface

Model # 2ESPwa_-R4824-QS-T_-_-

60.0" x 30.0" quick ship complete table

Weight Adjustable Espree 2-leg table base with a 60.0"w x 30.0"d rectangle TFL worksurface

Model # 2ESPWA_-R6030-QS-T_-_-

■ base finish notation ■ laminate color notation

Weight Adjustable Espree table

Quick ship complete table options include: silver, black or white table base; 48.0"w x 24.0"d or 60.0"w x 30.0"d rectangle worksurfaces; all six TFL laminates. For all other combinations, please call our Customer Service Department for the estimated lead time and cost.

- a: number of legs
- b: type of table base
- c: finish of base
- d: worksurface shape
- e: worksurface width
- f: worksurface depth
- g: quick ship indicator
- h: laminate material
- i: laminate color

Available base finishes

- Silver -S
- Black -B LT
- White -W LT

Available TFL quick ship laminates

- Beigewood - BG
- Phantom Charcoal -PC
- Shadow Oak -SO
- Designer White -DW
- Grey -GR
- Dove Grey -DV

Q Crank



Product specs

- Crank height adjustment
- 220 lb. base lifting capacity
- 1.0" per two cranks adjustment speed
- 17.5" height adjustment range
- - 24.8"–42.3" (low/high) (excluding worksurface)
- Two stage adjustable legs
- C-leg
- Adjustable width frame accommodates worksurfaces 36.0"–72.0"
- Locking casters are available
- Complete tables available (base and top)
- Warranty: Lifetime

Available base finishes

- Silver -SLV
- Black -BLK

Caster kit

Set of four caster wheels for table base
 Increases height by 2.0"
 Locking casters for security

Model # CASTERKIT-QCRANK

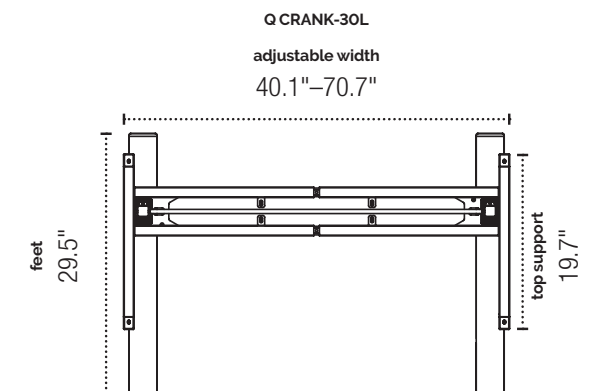
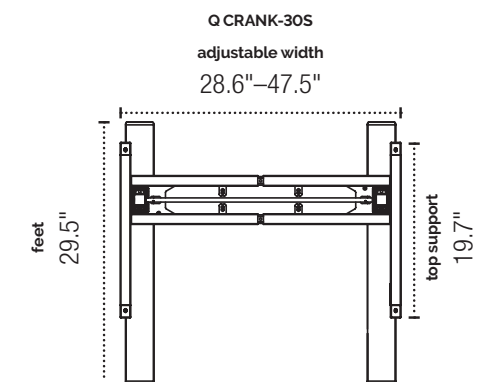
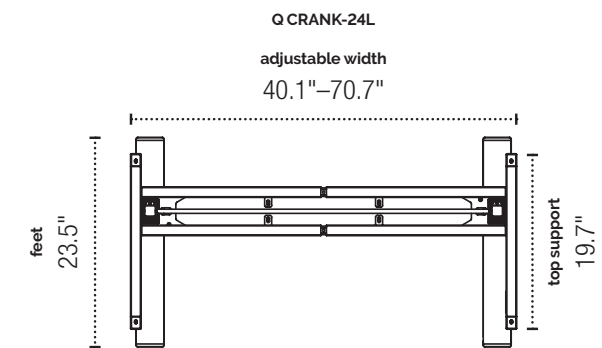
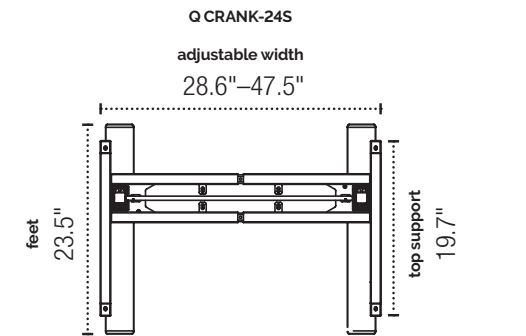

The base dimensions as shown are actual.

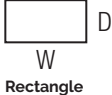
Table bases		Available worksurfaces				
Table base model #	Worksurface shape	Worksurface dimension	TFL standard		HPL standard	
			Quick ship	Standard ship	Standard ship	HPL premium
QCRANK-24S-___		36"w x 24"d	-	•	•	•
		42"w x 24"d	-	•	•	•
		48"w x 24"d	•	•	•	•
QCRANK-24L-___	Rectangle	60"w x 24"d	-	•	•	•
		72"w x 24"d	-	•	•	•
QCRANK-30S-___	Rectangle	36"w x 30"d	-	•	•	•
		42"w x 30"d	-	•	•	•
		48"w x 30"d	-	•	•	•
QCRANK-30L-___	Rectangle	60"w x 30"d	•	•	•	•
		72"w x 30"d	-	•	•	•



Q Crank complete table

Complete quick ship table model # breakdown:



2QC_-R4824-QS-T_-_-
 a b c d e f g h i

- a: number of legs
- b: type of table base
- c: finish of base
- d: worksurface shape
- e: worksurface width
- f: worksurface depth
- g: quick ship indicator
- h: laminate material
- i: laminate color

48.0" x 24.0" quick ship complete table

Q Crank 2-leg table base with a 48.0"w x 24.0"d rectangle TFL worksurface
 MODEL # 2QC--R4824-QS-T-

60.0" x 30.0" quick ship complete table







Q Crank 2-leg table base with a 60.0"w x 30.0"d rectangle TFL worksurface
 MODEL # 2QC--R6030-QS-T-

 base finish notation  laminate color notation

Available base finishes

-  Silver -S
-  Black -B

Available TFL quick ship laminates

-  Beigewood - BG
-  Phantom Charcoal -PC
-  Shadow Oak -SO
-  Designer White -DW
-  Grey -GR
-  Dove Grey -DV

Q Crank table

Quick ship complete table options include: silver and black table base; 48.0"w x 24.0"d or 60.0"w x 30.0"d rectangle worksurfaces; all six TFL laminates. For all other combinations, please call our Customer Service Department for the estimated lead time and cost.

Worksurfaces overview

How to order:

Worksurfaces have multiple model numbers based on worksurface dimensions.

ESI offers Thermally Fused Laminate (TFL) in 6 styles for both quick ship and standard worksurfaces. Additionally we offer High Pressure Laminate (HPL) in 14 standard styles and 6 premium styles.

Use the worksurface two letter color code to complete your model number.

Worksurface part number breakdown:

2R4824-TFL-DW

a | b | c | d | e

- a: worksurface shape
- b: worksurface width
- c: worksurface depth
- d: laminate material
- e: laminate color

This product number represents:
Rectangle shape
48.0" wide and 24.0" deep
TFL standard
Designer White laminate

General information:

Worksurfaces*

Worksurfaces can be sold separately or in combination with a table base.

Warranty: Lifetime



Sizing

Fellowes' worksurfaces are made to exact dimensions. If nominal sizing is needed, please specify when ordering. TFL worksurfaces are 1.0" thick. HPL worksurfaces are 1.125" thick.

Lead times

For standard colors and sizes the leads times are as follows. Lead time may vary depending on quantities ordered and their availability.

For custom sizes and laminates please see below:

TFL quick ship: 48 hours

TFL standard: Contact Customer Service for current lead times

HPL standard: Contact Customer Service for current lead times

HPL premium: Contact Customer Service for current lead times

Custom options

For more information on alternative worksurface shapes, thicknesses, edge detail, laminate options, and pre-drilling, contact our Customer Service Department. Extended lead times and upcharges will apply on all custom requests. Orders with custom laminates or custom edge detailing will both require a standard solid edge banding.

Worksurface pre-drilled holes

For your convenience, all quick ship worksurfaces will be pre-drilled to accommodate the VictoryLX 2-leg and the TriumphLX table bases. Pre-drilling for any other height adjustable table base series will require extended lead time and an additional cost.

Worksurfaces ship with standard square edge profile and coordinating 3mm edge band with a 3mm top radius. Alternative edge detail options are available at additional cost.

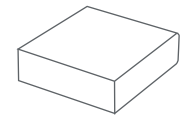

Square edge

Laminate materials

Worksurfaces are available in select Wilsonart® and Uniboard® laminate options. Fellowes worksurfaces are either Thermally Fused Laminates, High Pressure Laminates or Premium High Pressure Laminates. Please indicate laminate color choice by adding the 2-letter code at the end of the worksurface model number.

Thermally fused laminates (TFL) - quick ship and standard

Worksurfaces consist of a single printed decor paper fused directly by heat and pressure to the core material of MDF or particle board.

TFL benefits: cost efficient, consistent and uniform, water resistant, scratch resistant.

High pressure laminates (HPL) - standard and premium

Worksurfaces consist of a melamine treated printed decor paper fused to multiple sheets of kraft paper. Heat and pressure bond all the sheets together creating a flexible and durable piece of plastic type material which is then adhered to MDF or particle board.

Standard HPL benefits: durable, versatile, stylish, heat resistant, water resistant, scratch resistant, impact resistant, hygienic qualities.

Premium HPL benefits: Same as standard HPL, plus enhanced performance to durability and scratch resistance.

Edge detail

All register marks are property of their respective owners.

*Fellowes worksurfaces are specifically designed to work with Fellowes height adjustable table bases. If a different application is going to be used, please contact customer service for more details.

Worksurfaces

TFL quick ship worksurfaces

TFL quick ship worksurfaces ship within 48 hours and are available in six colors.

Available shapes and woodgrain pattern direction:

Please see the diagrams for the direction of the woodgrain pattern on each worksurface shape.

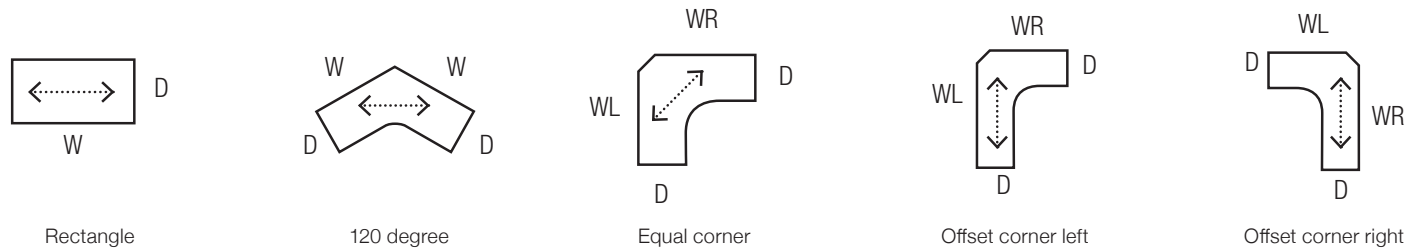

Worksurface dimensions:

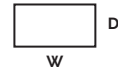
	Surface model	Dimensions
	2R4824-QS-TFL-__	48" w x 24"d
	2R6030-QS-TFL-__	60"w x 30"d

TFL standard worksurfaces

TFL standard worksurfaces are available in six colors.



Worksurface dimensions:

	Surface model	Dimensions		Surface model	Dimensions	
	2R3624-TFL-__	36"w x 24"d		3EC606024-TFL-__	60"wl x 60"wr x 24"d	
	2R4224-TFL-__	42"w x 24"d		3EC727224-TFL-__	72"wl x 72"wr x 24"d	
	2R4824-TFL-__	48"w x 24"d		3EC606030-TFL-__	60"wl x 60"wr x 30"d	
	2R6024-TFL-__	60"w x 24"d		3EC727230-TFL-__	72"wl x 72"wr x 30"d	
	2R7224-TFL-__	72"w x 24"d				
	2R3630-TFL-__	36"w x 30"d			3OCL604824-TFL-__	60"wl x 48"wr x 24"d
	2R4230-TFL-__	42"w x 30"d			3OCL724824-TFL-__	72"wl x 48"wr x 24"d
	2R4830-TFL-__	48"w x 30"d			3OCL726024-TFL-__	72"wl x 60"wr x 24"d
	2R6030-TFL-__	60"w x 30"d			3OCL844824-TFL-__	84"wl x 48"wr x 24"d
	2R7230-TFL-__	72"w x 30"d			3OCL604830-TFL-__	60"wl x 48"wr x 30"d
					3OCL724830-TFL-__	72"wl x 48"wr x 30"d
				3OCL726030-TFL-__	72"wl x 60"wr x 30"d	
				3OCL844830-TFL-__	84"wl x 48"wr x 30"d	
	120-4824-TFL-__	48"w x 24"d		3OCR486024-TFL-__	48"wl x 60"wr x 24"d	
				3OCR487224-TFL-__	48"wl x 72"wr x 24"d	
		3OCR607224-TFL-__		60"wl x 72"wr x 24"d		
		3OCR488424-TFL-__		48"wl x 84"wr x 24"d		
		3OCR486030-TFL-__		48"wl x 60"wr x 30"d		
		3OCR487230-TFL-__		48"wl x 72"wr x 30"d		
		3OCR607230-TFL-__		60"wl x 72"wr x 30"d		
		3OCR488430-TFL-__		48"wl x 84"wr x 30"d		

Table bases and worksurfaces can be purchased independently or as a combination. Fellowes worksurfaces are made to exact dimensions. If nominal sizing is needed, please specify when ordering.

HPL standard worksurfaces

HPL standard worksurfaces are available in 13 colors. Please see page 42 for the laminate options that are available.

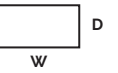
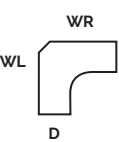
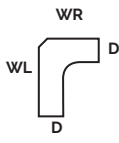
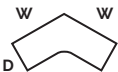
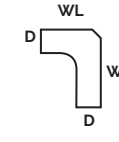

Worksurface dimensions:

Surface model	Dimensions
2R3624-HPL-__	36"w x 24"d
2R4224-HPL-__	42"w x 24"d
2R4824-HPL-__	48"w x 24"d
2R6024-HPL-__	60"w x 24"d
2R7224-HPL-__	72"w x 24"d
2R3630-HPL-__	36"w x 30"d
2R4230-HPL-__	42"w x 30"d
2R4830-HPL-__	48"w x 30"d
2R6030-HPL-__	60"w x 30"d
2R7230-HPL-__	72"w x 30"d

Surface model	Dimensions
120-4824-HPL-__	48"w x 24"d
120-6024-HPL-__	60"w x 24"d
120-7224-HPL-__	72"w x 24"d
120-4830-HPL-__	48"w x 30"d
120-6030-HPL-__	60"w x 30"d

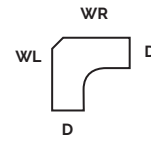

Surface model	Dimensions
3EC606024-HPL-__	60"wl x 60"wr x 24"d
3EC606030-HPL-__	60"wl x 60"wr x 30"d
3EC727224-HPL-__	72"wl x 72"wr x 24"d
3EC727230-HPL-__	72"wl x 72"wr x 30"d

Offset corner left

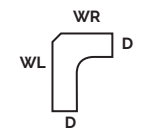

Surface model	Dimensions
3OCL604824-HPL-__	60"wl x 48"wr x 24"d
3OCL724824-HPL-__	72"wl x 48"wr x 24"d
3OCL844824-HPL-__	84"wl x 48"wr x 24"d
3OCL726024-HPL-__	72"wl x 60"wr x 24"d
3OCL846024-HPL-__	84"wl x 60"wr x 24"d
3OCL604830-HPL-__	60"wl x 48"wr x 30"d
3OCL724830-HPL-__	72"wl x 48"wr x 30"d
3OCL844830-HPL-__	84"wl x 48"wr x 30"d
3OCL726030-HPL-__	72"wl x 60"wr x 30"d

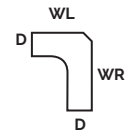

Surface model	Dimensions
3OCR486024-HPL-__	48"wl x 60"wr x 24"d
3OCR487224-HPL-__	48"wl x 72"wr x 24"d
3OCR488424-HPL-__	48"wl x 84"wr x 24"d
3OCR607224-HPL-__	60"wl x 72"wr x 24"d
3OCR608424-HPL-__	60"wl x 84"wr x 24"d
3OCR486030-HPL-__	48"wl x 60"wr x 30"d
3OCR487230-HPL-__	48"wl x 72"wr x 30"d
3OCR488430-HPL-__	48"wl x 84"wr x 30"d
3OCR607230-HPL-__	60"wl x 72"wr x 30"d
3OCR608430-HPL-__	60"wl x 84"wr x 30"d

HPL premium worksurfaces

HPL premium worksurfaces are available in six colors. Please see page 42 for the laminate options that are available.



Worksurface dimensions:

Surface model	Dimensions
2R3624-PHPL-__	36"w x 24"d
2R4224-PHPL-__	42"w x 24"d
2R4824-PHPL-__	48"w x 24"d
2R6024-PHPL-__	60"w x 24"d
2R7224-PHPL-__	72"w x 24"d
2R3630-PHPL-__	36"w x 30"d
2R4230-PHPL-__	42"w x 30"d
2R4830-PHPL-__	48"w x 30"d
2R6030-PHPL-__	60"w x 30"d
2R7230-PHPL-__	72"w x 30"d

Surface model	Dimensions
120-4824-PHPL-__	48"w x 24"d
120-6024-PHPL-__	60"w x 24"d
120-7224-PHPL-__	72"w x 24"d
120-4830-PHPL-__	48"w x 30"d
120-6030-PHPL-__	60"w x 30"d

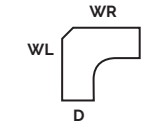
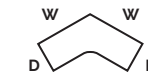
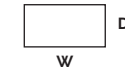

Offset corner left

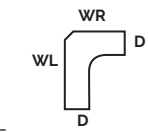

Surface model	Dimensions
3EC606024-PHPL-__	60"wl x 60"wr x 24"d
3EC606030-PHPL-__	60"wl x 60"wr x 30"d
3EC727224-PHPL-__	72"wl x 72"wr x 24"d
3EC727230-PHPL-__	72"wl x 72"wr x 30"d

Surface model	Dimensions
3OCL604824-PHPL-__	60"wl x 48"wr x 24"d
3OCL724824-PHPL-__	72"wl x 48"wr x 24"d
3OCL844824-PHPL-__	84"wl x 48"wr x 24"d
3OCL726024-PHPL-__	72"wl x 60"wr x 24"d
3OCL846024-PHPL-__	84"wl x 60"wr x 24"d
3OCL604830-PHPL-__	60"wl x 48"wr x 30"d
3OCL724830-PHPL-__	72"wl x 48"wr x 30"d
3OCL844830-PHPL-__	84"wl x 48"wr x 30"d
3OCL726030-PHPL-__	72"wl x 60"wr x 30"d

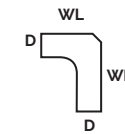

Surface model	Dimensions
3OCR486024-PHPL-__	48"wl x 60"wr x 24"d
3OCR487224-PHPL-__	48"wl x 72"wr x 24"d
3OCR488424-PHPL-__	48"wl x 84"wr x 24"d
3OCR607224-PHPL-__	60"wl x 72"wr x 24"d
3OCR608424-PHPL-__	60"wl x 84"wr x 24"d
3OCR486030-PHPL-__	48"wl x 60"wr x 30"d
3OCR487230-PHPL-__	48"wl x 72"wr x 30"d
3OCR488430-PHPL-__	48"wl x 84"wr x 30"d
3OCR607230-PHPL-__	60"wl x 72"wr x 30"d
3OCR608430-PHPL-__	60"wl x 84"wr x 30"d

Table bases and worksurfaces can be purchased independently or as a combination.

Fellowes worksurfaces are made to exact dimensions. If nominal sizing is needed, please specify when ordering.

Table bases and worksurfaces can be purchased independently or as a combination.

Fellowes worksurfaces are made to exact dimensions. If nominal sizing is needed, please specify when ordering.

Laminates

TFL options: Available for TFL standard worksurfaces and for 48 hour quick ship

Patterns



Color code: BG
Color name: Beigewood
Finish: Matte
Manufacturer: Wilsonart
Wilsonart Part #: 7850-60



Color code: PC
Color name: Phantom Charcoal
Finish: Matte
Manufacturer: Wilsonart
Wilsonart Part #: 8214K-28



Color code: SO
Color name: Shadow Oak
Finish: Matte
Manufacturer: Uniboard
Uniboard Part #: 762

Solids



Color code: DW
Color name: Designer White
Finish: Matte
Manufacturer: Wilsonart
Wilsonart Part #: D354-60



Color code: GR
Color name: Grey
Finish: Matte
Manufacturer: Wilsonart
Wilsonart Part #: 1500-60

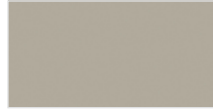

Color code: DV
Color name: Dove Grey
Finish: Matte
Manufacturer: Wilsonart
Wilsonart Part #: D92

HPL standard options: Available for HPL standard worksurfaces

Patterns



Color code: MM
Color name: Manitoba Maple
Finish: Matte
Manufacturer: Wilsonart
Wilsonart Part #: 7911-60



Color code: BG
Color name: Beigewood
Finish: Matte
Manufacturer: Wilsonart
Wilsonart Part #: 7850-60

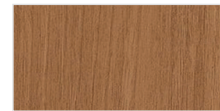

Color code: BZ
Color name: Brazilwood
Finish: Fine velvet
Manufacturer: Wilsonart
Wilsonart Part #: 7946-38

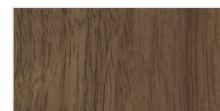

Color code: PW
Color name: Pinnacle Walnut
Finish: Fine velvet
Manufacturer: Wilsonart
Wilsonart Part #: 7992-38

Solids

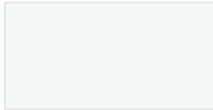

Color code: DW
Color name: Designer White
Finish: Matte
Manufacturer: Wilsonart
Wilsonart Part #: D354-60



Color code: LN
Color name: Linen
Finish: Matte
Manufacturer: Wilsonart
Wilsonart Part #: D427-60

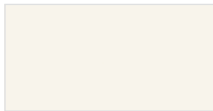

Color code: AQ
Color name: Antique White
Finish: Matte
Manufacturer: Wilsonart
Wilsonart Part #: 1572-60

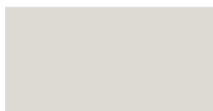

Color code: GR
Color name: Grey
Finish: Matte
Manufacturer: Wilsonart
Wilsonart Part #: 1500-60



Color code: PL
Color name: Platinum
Finish: Matte
Manufacturer: Wilsonart
Wilsonart Part #: D315-60



Color code: KB
Color name: Khaki Brown
Finish: Matte
Manufacturer: Wilsonart
Wilsonart Part #: D50-60



Color code: SH
Color name: Shadow
Finish: Matte
Manufacturer: Wilsonart
Wilsonart Part #: D96-60



Color code: SL
Color name: Slate Grey
Finish: Matte
Manufacturer: Wilsonart
Wilsonart Part #: D91-60

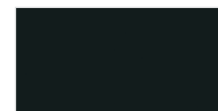

Color code: BK
Color name: Black
Finish: Matte
Manufacturer: Wilsonart
Wilsonart Part #: 1595-60

HPL premium options: Available for HPL premium worksurfaces

Patterns



Color code: PP
Color name: Phantom Pearl
Finish: Gloss line finish with Aeon
Manufacturer: Wilsonart
Wilsonart Part #: 8211K-28



Color code: WH
Color name: Walnut Heights
Finish: Soft grain finish with Aeon
Manufacturer: Wilsonart
Wilsonart Part #: 7965K-12



Color code: PE
Color name: Phantom Ecru
Finish: Gloss line finish with Aeon
Manufacturer: Wilsonart
Wilsonart Part #: 8212K-28



Color code: EM
Color name: Empire Mahogany
Finish: Fine velvet
Manufacturer: Wilsonart
Wilsonart Part #: 7122T-38



Color code: PC
Color name: Phantom Charcoal
Finish: Gloss line finish with Aeon
Manufacturer: Wilsonart
Wilsonart Part #: 8214K-28



Color code: AN
Color name: Asian Night
Finish: Linearity Finish with Aeon
Manufacturer: Wilsonart
Wilsonart Part #: 7949K-18

Mobile tables

Motific™ Height Adjustable

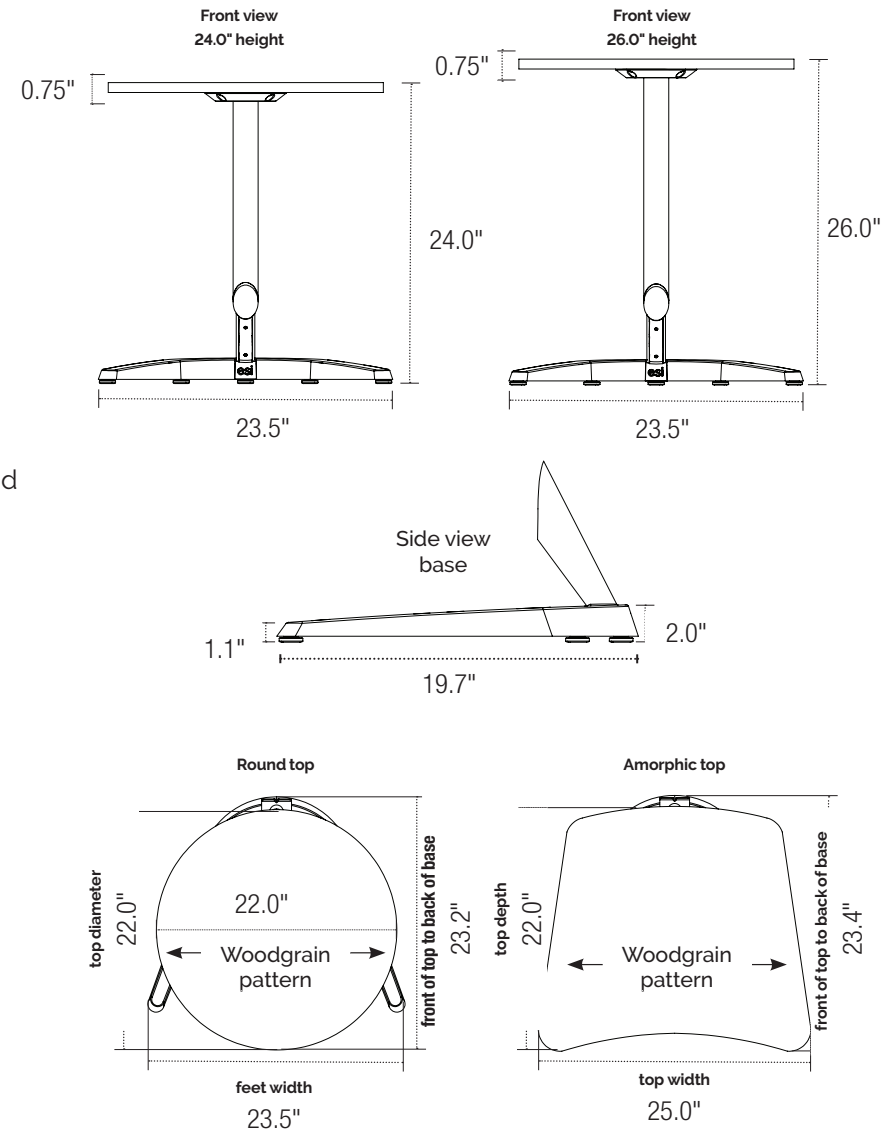

Product specs

- Laptop or occasional table
- Multiple color combinations for unique and elegant design options
- Thermofoil formed top
- 2 available top sizes, 0.75" thick:
- Round 22.0" diameter
- Amorphic 25.0" width and 22.0" depth
- 5.5" height adjustment range - 22.5"–27.8"(low/high) (excluding top)
- Includes an accessory hook
- Non-marring, easy-to-slide glides
- 25 lb. max weight capacity
- Base dimensions
- 19.7" depth
- 23.5" width (widest point)
- Lifetime Warranty

The base dimensions as shown are actual.

Base Model

MOADJSS

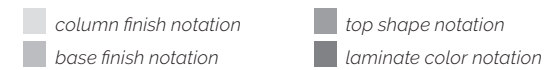

The combination of a silver column and silver base with either shape top in Amati Walnut or Designer White is available to ship in 48 hours.

Available column finishes:

- Silver -S
- Black -B LT
- White -W LT

Available base finishes:

- Silver -S
- Black -B LT
- White -W LT
- Polished Aluminum -A LT

Available tops and colors:

- Round -RND
- Amati Walnut -AW
- Designer White -DW
- Amorphic -AMP
- Amati Walnut -AW
- Designer White -DW

Woodgrain pattern runs left to right.

Terms & Conditions

Global Terms and Conditions of Sale

(All Locations)

These terms shall be considered to be an inseparable part of any additional terms between the applicable Fellowes entity and Customer and are collectively referred to herein as the Terms and Conditions. To the extent that any terms provided by Customer conflict with the terms and conditions that follow, these Terms and Conditions shall govern that transaction.

Acceptance; Entire Agreement.

Acceptance by Customer of delivery of goods constitutes acceptance by Customer of the following terms and conditions. Any additional or different terms proposed by Customer shall be deemed to have been objected to by the Fellowes entity ("Fellowes" or "Seller"), shall be of no force or effect, and shall not be binding upon or enforceable against Seller. These terms and conditions constitute the entire agreement and understanding between the parties and supersede any and all prior agreements, understandings and communications with Customer, oral or written, relating to the goods that Seller or any of its subcontractors may provide (collectively, the "Goods"). No course of dealing or course of performance, either prior to, during or after the delivery of the Goods, shall be relevant or admissible by Customer to supplement, explain or vary these Terms and Conditions. The invalidity or unenforceability of any Terms and Conditions shall not affect the validity or enforceability of any other term or condition, and the remaining terms and conditions shall remain in full force and effect. No waiver, amendment or modification of these Terms and Conditions shall be binding upon or enforceable against Seller until approved in writing by a Fellowes Authorized Signatory.

Proprietary Information; Confidentiality.

Advertising. Customer shall consider all information furnished by Fellowes, as well as information learned about Fellowes' business or products, to be confidential and shall not disclose any such information to any other person or entity or use such information itself for any purpose other than performing hereunder, unless Customer obtains written permission from Fellowes to do so. This paragraph shall apply to drawings, specifications, or other documents prepared by Customer or Fellowes in connection with this order as well as observations of Customer while receiving goods or services. Customer shall not advertise or publish the fact that Fellowes has contracted to sell goods or services to Customer, nor shall any information relating to the order be disclosed without Fellowes' written permission unless otherwise agreed in writing, no commercial financial or technical information disclosed in any manner or at any time by Customer to Fellowes shall be deemed secret or confidential and Customer shall have no rights against Fellowes with respect thereof except such rights as may exist under patent or copyright laws.

Trademark Rights.

Fellowes grants Customer a non-exclusive, royalty-free license to use the Fellowes' trademarks included on any goods purchased hereunder (the "Licensed Marks") in connection with Customer's sale or marketing of goods in the course of Customer's business. The license granted herein does not include a right to sublicense. Customer acknowledges that Fellowes is the owner of the Licensed Marks, and nothing herein shall grant to Customer any right, title or interest in the Licensed Marks, except as specifically set forth herein. Customer shall use Fellowes' trademarks in a manner that is consistent with Fellowes' standards. This includes using the ® designation adjacent to registered trademarks, and the TM designation adjacent to unregistered trademarks, where practicable.

Customer shall cooperate with Fellowes' requests to ensure that Fellowes' trademarks are used in this manner. Fellowes shall have the right to review and inspect any marketing or promotional materials relating to the Licensed Products and, in its sole discretion, to prohibit the use of any such materials that do not meet Fellowes' standards. If Customer becomes aware of any infringing products, Customer will promptly notify Fellowes, which reserves the right to take any action. This trademark license is revocable at Fellowes' sole discretion.

Prices.

Prices quoted by Fellowes are subject to change without notice. Prices billed on invoice at time of shipment shall govern. Unless otherwise stated, all prices are quoted in U.S. Dollars. Seller will not accept or process purchase orders that contain pricing different from the standard prices. Fellowes reserves the right to revise all pricing, discounts, and freight terms, at any time, without notice. Current product pricing is included on product pages at Fellowes.com. Prices which are in effect at the time of order shall apply. Listed prices exclude additional fees applicable to special services requested by Customer (e.g., special cutting).

Taxes.

The prices for the Goods do not include sales, use and other taxes, duties and other governmental fees and charges that may be applicable to the Goods, and Customer shall be responsible for and pay upon demand all such taxes, duties and other governmental fees and charges (other than income taxes of Seller), notwithstanding that responsibility for collection or payment of such taxes, duties and other governmental fees and charges may be imposed by law on Seller or any of its subcontractors. All authorized dealers should ensure that a resale tax exemption certificate is on file with Fellowes.

Discontinued products.

Due to changing market demands, Fellowes may periodically discontinue certain products. Fellowes reserves the right to change and/or discontinue products at any time without notice.

Credit.

Fellowes may, in its sole discretion, extend credit to the Customer. For credit limits in excess of \$100,000, Fellowes requires audited financial statements prior to initial credit approval and on an annual basis thereafter. Fellowes shall perform periodic credit reviews using credit reporting agencies, trade references, industry trade groups and banks. In the event of a material adverse change in Customer's credit standing or in the event that Customer does not comply with the terms of these provisions, Fellowes shall have the right to change terms of payment, and Fellowes obligation to provide Products will be subject to reaching mutual agreement on revised terms.

To establish an account, Customer must complete and submit Fellowes' New Account Application (signed by company officer of Customer), Federal Taxpayer ID (Form W-9) and State Resale Certificate. Subject to sales, credit history, and credit lines, a deposit or advance payment may be required to process large orders.

Once credit is approved, payment terms are net 30 days. Prior to Customer's credit approval (with receipt of required documents), prepayment of orders may be made by corporate check, wire transfer or ACH or for convenience, credit cards (Visa and Mastercard) are accepted.

Payment.

Unless otherwise agreed in writing or stated on the Invoice, all payments are to be made in US Dollars and all amounts payable by Customer shall be due and payable in full 30 days after invoice. Fellowes will not accept the unilateral assessment of any fee, marketing support, co-op or other advertising, expense reimbursement, rebate, offset or any other financial or marketing support not explicitly authorized in writing by an authorized officer of Seller.

Any amounts not paid in full within 30 days after invoice shall be subject to a late payment charge of 1 ½ % per month (or, if less, the maximum amount permitted by law) from the date due until paid. Fellowes' obligation to provide Products is subject to receipt of prompt payment of all invoices pursuant to the terms of this and other agreements we may have with Customer. Progress billing of interest due or a failure to bill for interest due shall not constitute a waiver of Fellowes' right to charge interest on all amounts past due to the date payment is received. Should any portion of an invoice become disputed you agree to pay the undisputed portion according to its terms, and you will notify us promptly of the dispute.

Both parties agree to use their best efforts to resolve the disputed portion of such invoice within 30 days. Fellowes shall have the right to set off against any amount that Fellowes may be obligated to pay to Customer any amounts due or to become due to Fellowes from Customer and its divisions, subsidiaries and affiliated companies. Fellowes may assign payments due to a wholly-owned subsidiary without consent.

Order Placement and Confirmation.

(a)Stocked Finished Goods (Workspace Category). Fellowes be submitted via e-mail to

ci-orders@Fellowes.com. Orders must include "Ship To" and "Bill To" information along with complete Fellowes product model numbers and Customer cost. Government orders require a copy of the agency PO at the time the order is placed with Fellowes. All orders shall be subject to written acceptance by an authorized representative of Fellowes. Incomplete orders or changes will delay processing and shipment until receipt of all necessary information and Fellowes issuance of revised Sales Order Acknowledgment.

(b)For Made-to-Order, Special, and Custom Products (Furniture, Modular Walls, and Air Quality Management Categories)

Fellowes requires all orders to be submitted electronically via on-line order entry at www.fellowes.com, or in writing following Ordering Procedures. Fellowes recommends using design software for larger projects which allows the dealer to design, specify, and enter an order more efficiently and accurately which will assure completeness and avoid errors and duplications. Customer assumes all responsibility for the correct content of any order which has been acknowledged.

Upon receiving an order, Fellowes will send an acknowledgement with exact pricing information and a scheduled shipping date. Orders can also be confirmed on-line at www.fellowes.com. Customer is responsible for checking acknowledgements to ensure that the order is correct. Order will be processed as acknowledged.

Order changes or cancellations.

All Customer cancellations and changes must be submitted to Fellowes in writing to ci-orders@Fellowes.com. **Any request for**

cancellation or change to an order must be submitted within twenty-four (24) hours of receipt of order acknowledgement by Fellowes. Any requested cancellation or change received thereafter will incur a fee. Order changes include the addition/deletion of line items or changes in quantity or requested Ship Date or Ship To address. Order changes that result in a quantity reduction may be subject to an adjustment in pricing. Change or cancellation requests are not considered accepted until Fellowes provides a revised Sales Order Acknowledgment. Changes may result in processing delays or shipping delays. Under no circumstances will changes or cancellations be accepted on any special order, custom product, or worksurface order without the express written consent of Fellowes. All such custom and special orders are non-returnable.

Lead-Times and Delays.

Fellowes reserves the right to alter lead times as demand for products fluctuate. Stated lead- times begin after a complete order is entered and scheduled. Shipments are subject to product availability. Special products and larger orders may entail extended lead-times. Orders placed by dealers without a requested delivery date will be assigned a delivery date for custom product orders as currently published at www.fellowes.com. Please contact your customer service representative for estimated lead-times. If unforeseen circumstances occur, Fellowes may postpone delivery of orders and will notify Customer when such postponement occurs.

Fellowes shall not be liable for loss or damage due to delay in manufacturing or delivery resulting from any cause beyond Fellowes' reasonable control. This includes, but is not limited to, compliance with any regulations, orders, or instructions of any Federal, State, or Municipal Government, or any department or agency thereof, acts of God, acts or omissions of Customer, acts of civil or military authority, fires, strikes, disease or pandemic, factory shutdowns or alterations, embargoes, war, riot, delays in transportation or inability due to causes beyond Fellowes' reasonable control to obtain necessary labor, manufacturing facilities, or material from Fellowes' usual sources. In no event shall Fellowes be liable for special or consequential damages for any delay for any cause.

Shipping and Transportation.

(a)For Stocked Finished Goods
48-hour shipping program

Fellowes offers 48-hour shipping on the majority of finished goods in that are in stock. Unless otherwise requested, these products are shipped from multiple shipping points throughout the U.S., within two business days of receiving the PO, depending on quantity ordered and available inventory. Orders that include products with longer lead times including special orders, custom products, or worksurface orders, are designated as "LT" (lead time) and therefore excluded from the 48-hour shipping program. Large orders may also require additional lead time. Products designated as LT could take up to 90 days for delivery after Fellowes' receipt of Customer's order. Call for on-hand availability.

Please note:

- For the order to qualify for 48-hour shipping, all products on the PO must be available under the 48-hour shipping program.
- POs that include LT designated products will be shipped based on the lead time of the LT designated products unless otherwise requested.

3. 48-hour orders will be shipped out within two business days of Fellowes' receipt of Customer's order unless otherwise specified on the PO.

4. Worksurfaces, Motific, Centro, and Railway may arrive on a date different than the other items on the order.

For all other purchases, delivery dates for the Goods shall be established by mutual agreement of Fellowes and Customer. The minimum order size is \$1500. Fellowes may at its option accept orders not meeting the minimum order size with a \$75 handling fee. Customer shall provide any special shipping or labeling requirements to Fellowes for consideration prior to the first shipment.

Freight terms are as follows:

- Orders under \$2,500 list will incur a flat \$25 net fee
- Orders between \$2,501 list and \$5,000 list will incur a flat \$100 net fee
- Orders between \$5,001 list and \$7,000 list will incur a flat \$200 net fee
- Order overs \$7,001 list ship free
- Residential freight deliveries will incur a flat \$70 net fee.

For Canada:

- Orders under \$3,125 (CAD) list will incur a flat \$50 (CAD) net fee
- Orders between \$3,126 (CAD) list and \$6,250 (CAD) list will incur a flat \$125 (CAD) net fee
- Orders between \$6,251 (CAD) list and \$9,375 (CAD) list will incur a flat \$250 (CAD) net fee
- Orders over \$9,376 (CAD) list ship free.
- Residential freight deliveries will incur a flat \$140 (CAD) net fee.

Fellowes ships orders by way of standard ground carrier service dock-to-dock within the contiguous 48 states of the United States. Special requests such as "call before delivery", "delivery lift gate required", residential delivery, re-routed deliveries, or specific delivery date/time requests may be subject to additional charges or may not be available. Contact our Customer Service Department for expedited delivery requests or deliveries outside of the contiguous 48 states. Customers will be charged additional fees for changes made to orders that have already departed the facility, resulting in re-delivery or re- consignment.

Fellowes accepts requests for expedited freight at the customer's expense. Please contact our Customer Service Department at 800.833.3746 and provide your preferred carrier account number in which to charge the expedited freight.

Unless an Invoice expressly specifies otherwise, all Goods shall be delivered F.O.B. the shipping platform at the shipping facility, and all shipping and transportation costs from the shipping platform at such facility shall be borne by Customer and all risk of loss, damage or late delivery shall pass to Customer upon loading at the shipping platform at such facility. Seller shall have no responsibility for any failure of or delay in delivery caused by or attributable to war, sabotage, riot, civil disorder, fire, flood, earthquake, explosion, accident, natural or manmade disaster, governmental action, shortage or interruption of supply of materials, supplies, equipment or energy, transportation problem, strike, labor stoppage or slowdown, or other cause beyond the reasonable control of Seller.

(b)For Made-to-Order, Special, and Custom Products

All orders shipped to any destination within the contiguous United States, will be F.O.B. origin, freight prepaid. Except as noted above, title and risk of loss or damage shall pass to Customer upon delivery to carrier. Fellowes shall retain a Purchase Money Security Interest in all such goods until payment is received in full and reserves the right to file and perfect the same. Fellowes will determine the method and agency of transportation to be used.

Exceptions to standard prepaid freight are as follows:

- Customer directed expedites (Air Freight, Team Hauls) will be prepaid by Fellowes and Customer will be billed the difference between standard and expedited freight.
- Truckload deliveries that are requested to deliver on weekends, Holidays or after 12:00 noon EST on Fridays will have an additional charge of \$450 per truck.
- Excessive unloading (in excess of 2 hours) will be billed at \$50 per hour after the initial 4 hour unloading period.
- LTL shipments normally deliver between 8:00 am and 5:00 pm, Monday through Friday. A specific delivery time on your assigned delivery date can be requested for an additional charge of \$150. This charge does not apply to full-truckload shipments. Requests for specific dates/times falling outside standard delivery timeframe for the carrier serving your area constitute Expedites (see Customer-Directed Expedites, above). Expedite charges do apply to full-truckload shipments.
- Lift gate service will have an additional charge of \$85 for an LTL carrier. For lift gate service on a truckload, contact Customer Service.
- Inside delivery service starts at \$50. Call Customer Service for quote.
- Reconsignment cost after shipment starts at \$50. Call Customer Service for quote.
- Special equipment requirements call for a quote.

If delivery is made on Fellowes owned or leased equipment, Customer or its authorized representative is responsible for noting any freight damage or shortage on the freight bill of lading at time of delivery and must notify Fellowes within five (5) days of delivery day of any such damage or shortage. Assistance in a concealed damage claim will be provided by Fellowes only if the product has been immediately unpacked and both the carrier and Fellowes have been promptly notified of resultant damage so the proper inspection can be made.

Damage and Shortage.

Fellowes is not responsible for shipped products when the common carrier is in receipt of the material. Fellowes expects all customers to thoroughly inspect orders on receipt regardless of point of delivery. Clear receipt should not be given on the material until it has been checked for damage in transit. All claims for noted damaged material must be made by the Customer to Fellowes Customer Service. Concealed damage or damage not noted at time of delivery shall be made by the Customer to the common carrier within five (5) days after receipt. Fellowes assumes no liability for such damage. Shortage on ordered products must be reported to Fellowes within five (5) days of product delivery and must be noted on the bill of lading at time of delivery.

Storage.

When shipment is delayed by the Customer, Fellowes reserves the right to place the goods in

storage at Customer's risk and cost. Fellowes charges ¼ of 1% of list price per week to cover storage. All terms and conditions of the sale, including but not limited to invoicing and payment, will continue to apply to Customer's confirmed order; except that title shall remain with Fellowes. Fellowes reserves the right to modify payment terms to assure recovery of any additional cost incurred.

Returned Goods.

To receive authorization to return goods, please contact Fellowes' Customer Service Department. All Returned Materials Authorizations expire thirty (30) days from date of issue. Any product returned after thirty (30) days will be refused and returned to sender collect. Electrical components, nonstandard items and fabric-covered goods may not be returned. Replacement products will be billed to you with credit being issued upon return of the product in good condition. All goods returned must be in the original Fellowes packaging. Goods will be inspected for damage upon return. No credit will be issued for goods which are damaged. A return authorization will not be issued for items unless they are Fellowes stock items. If material is authorized for return because of Fellowes error, shipment may be made freight collect. Any other goods that Fellowes authorizes a return will be sent prepaid and a restocking charge of 35% will apply.

Fellowes offers free returns for any accessory product returned in the original Fellowes packaging.

Fellowes does not accept returns of any made to order, special or custom product.

Installation.

Installation and servicing of Fellowes products are normally handled directly by Fellowes-authorized dealers. When this is not possible, assistance is available by calling Fellowes' Customer Service Department. On-site field measurement and installation support is available as a service. The fees are listed below:

Field Installation Assistance: 2 Day On-Site, \$1,200

Field Installation Assistance: 3 Days On-Site, \$1,800

Field Installation Assistance: 4 Days On-site, \$2,400

Field Installation Assistance: 5 Days On-Site, \$3,000

*Days include 1/2 day travel to and 1/2 day travel from location. These fees are based on a minimum fourteen (14) business days advanced notification and booking.

*Service requests booked less than fourteen (14) business days in advance may be subject to additional fees due to added travel cost. For more information or to place a request, contact Fellowes Customer Service at 1-800-833-3746.

Product Usage and Compliance.

Customer assumes full responsibility for the application of Fellowes' product to Customer's use and compliance with Fellowes installation and maintenance instructions and reasonable load restrictions. Compliance to local code restrictions regarding fire, electrical, and building codes are the responsibility of the Customer or its authorized agent.

Customer's Own Material or COM.

The Fellowes COM program allows customers to use special materials. By complying with the COM testing procedure in the steps below, Fellowes will be able to identify if your material is appropriate

for application to the products you specify. To comply with the COM process, please follow these steps:

1. Select the COM material.
2. Check first with www.fellowes.com/, and consult the COM library to determine if this material has already passed testing for manufacturability on the intended product.
3. If the material is pre-approved in the COM Library, customer must submit a COM Order Submission Form (avail- able from Fellowes Customer Service Representative).
4. If the material requested is not in the COM Library, customer must submit a COM test request on-line at www.fellowes.com, send a sample of the COM material (see Test Yardage Requirements below) and include a list of Fellowes product numbers designated for the COM application. Material sample should include pattern name, pattern number and color, manufacturer, direction material should be applied, and Control number from the COM Request Form automated e-mail response.
5. Ship COM samples to U.S. Mail and UPS/ FedEx Shipment: Fellowes - Attn: COM Request 13467 Quincy Street Holland, MI 49424
6. You will be notified within five working days of receiving the material sample by Fellowes, whether your COM has been approved or disapproved for application

TEST YARDAGE REQUIREMENTS		
TrendWall and Volo Tiles	4	yards
Fabric Screens	2	yards
Choices Panels	1 1/2	yards
Capture Tiles, Intrinsic Freestanding Ped Cushions, and Tackboards	1	yard
Flipper Doors	2/3	yard

NOTE: Most fabric houses have a yard- age minimum or an upcharge on less than one-yard cuts.

NOTE: All COM applications are priced at Grade 1 or Grade A.

If Customer desires to use its own material in the production of Fellowes' products, it is necessary to obtain the prior written consent of Fellowes. Whether purchased by Customer or by Fellowes on Customer's behalf, material provided by the Customer shall be shipped to Fellowes at Customer's sole expense and risk of loss. Fellowes will hold Customer's own materials for up to one (1) year from the date of receipt and thereafter return or dispose of such material at Customer's sole cost and expense.

Customer hereby holds Fellowes harmless against any and all claims for loss, liability, injury, or damage arising from use of Customer-provided material; and Customer takes full responsibility for performance and quality of Customer-provided material. Customer should also be aware that Customer-provided materials may not qualify for UL Listings and may not meet fire codes. Please discuss specific concerns and special needs with Fellowes Customer Service before to placing your order.

Custom Color.

Fellowes' Custom Color program allows the customer to specify their own color on many of Fellowes' products. See www.fellowes.com for product availability, individual product guidelines and lead times. Set up fees and lead times are product specific and will vary.

To request a Custom Color:

1. Complete a Custom Color Request form (available on www.fellowes.com).
2. Send request form along with two 2"x3" samples to Fellowes Customer Service Color Coordinator.
3. After the receipt of the request, Fellowes will provide customer with one color sample.
4. If approved, Dealer or customer completes custom color form, providing the custom match color number on the back of the sample, signs, and returns by fax or mail to Custom Color Coordinator.
5. Samples will be matched under cool white florescent lighting. All orders processed under the Custom Color program will be manufactured within commercially acceptable tolerances.
6. If applicable, dealer will be sent an invoice for \$250 color matching fee per customer, per color. See Specials Request form for details.

Limited Warranty; Limitations on Liability.

Fellowes grants a limited warranty to the end-users of its Goods, the terms of which are included with each product. Fellowes warrants to the Customer solely that, subject to the terms, conditions and limitations hereof, the Goods conform to the specifications set forth in the Fellowes catalog and will be transferred to customer free and clear of any and all encumbrances. **FELLOWES MAKES NO OTHER WARRANTIES AND GIVES NO OTHER ASSURANCES OR GUARANTEES, EXPRESS OR IMPLIED, WITH RESPECT TO ANY GOODS, INCLUDING, WITHOUT LIMITATION, ANY WARRANTY OF FITNESS FOR A PARTICULAR PURPOSE.**

FELLOWES' SOLE LIABILITY IN CONNECTION WITH ANY GOODS THAT ARE DEFECTIVE OR DELIVERED LATE SHALL BE LIMITED TO EITHER (i) REFUNDING TO THE CUSTOMER A PERCENTAGE OF THE TOTAL PRICE (EXCLUSIVE OF TAXES, SHIPPING AND OTHER SEPARATE CHARGES) THAT THE CUSTOMER HAS PAID TO FELLOWES FOR ALL GOODS PROVIDED EQUAL TO THE PERCENTAGE OF ALL GOODS PROVIDED THAT ARE DEFECTIVE OR DELIVERED LATE DUE TO THE SOLE FAULT OF FELLOWES AND ITS SUBCONTRACTORS, OR (ii) AT FELLOWES' OPTION, REPLACING FOR THE CUSTOMER, AT NO CHARGE TO THE CUSTOMER, THE GOODS THAT ARE DEFECTIVE OR DELIVERED LATE DUE TO THE SOLE FAULT OF FELLOWES AND ITS SUBCONTRACTORS.

IN NO EVENT SHALL FELLOWES OR ANY OF ITS SUBCONTRACTORS BE LIABLE FOR (i) ANY INCIDENTAL, INDIRECT, EXEMPLARY, SPECIAL OR CONSEQUENTIAL DAMAGES (INCLUDING, BUT NOT LIMITED TO, INTEREST, LOST PROFITS OR INTERRUPTION OF BUSINESS), EVEN IF FELLOWES HAS BEEN ADVISED OF THE POSSIBILITY OF SUCH DAMAGES OR IF SUCH DAMAGES RESULT FROM ANY RECOMMENDATIONS MADE BY FELLOWES, OR (ii) ANY LOSSES, DAMAGES, LIABILITIES, SUITS OR CLAIMS THAT ARE COVERED BY ANY INSURANCE MAINTAINED BY OR ON BEHALF OF THE CUSTOMER OR ARE OTHERWISE RECOVERABLE FROM THIRD PARTIES.

IN ADDITION, THE LIABILITY OF FELLOWES AND ITS

SUBCONTRACTORS FOR LOSSES, DAMAGES, LIABILITIES, SUITS AND CLAIMS, REGARDLESS OF THE FORM OF ACTION (WHETHER BASED ON CONTRACT, ON NEGLIGENCE, ON STRICT LIABILITY OR OTHERWISE) AND THE PERSON OR ENTITY BRINGING SUCH ACTION, SHALL NOT EXCEED, IN THE AGGREGATE, THE TOTAL AMOUNT (EXCLUSIVE OF TAXES, SHIPPING, AND OTHER SEPARATE CHARGES) ACTUALLY PAID TO SELLER BY THE CUSTOMER FOR THE GOODS AT ISSUE. ANY ACTION AGAINST SELLER MUST BE BROUGHT WITHIN ONE YEAR OF THE CAUSE OF ACTION FIRST ARISING.

Lifetime Warranty.

Fellowes warrants to the original purchaser that the products described in its price lists, sold after March 1, 2023, will be free from defects in materials and workmanship commencing with the date of initial purchase and continuing for as long as the original owner uses these products. This warranty provides limits on the following products:

	Products	Components
10 Years	<ul style="list-style-type: none"> • Lighting • Power Solutions • Hana Series • Palm Rests/Mouse Pads/ Pencil Drawers 	<ul style="list-style-type: none"> • Panel and Wall Textiles
5 Years		<ul style="list-style-type: none"> • Upholstered Cushions • PET and Acrylic Screens and Modesties • Seating Mesh • Plastic Components • Paint
Not Covered		<ul style="list-style-type: none"> • Customer's Own Material • Custom Requested Logos • Special Paint Textures and Finishes

The following exceptions apply to all product lines:

The Fellowes warranty applies to normal Eight hour, Forty hours per week office use.

Damage caused by improper treatment of the product including exposure to unusual environmental conditions (extreme climates, acids, and moisture)

This comprehensive warranty applies to all products installed or reconfigured by a Fellowes authorized installer. Fellowes will repair, or at its sole option, replace defective merchandise, free of charge, which, when used normally and pursuant to Fellowes' published instructions, and applicable planning guide information, prove to be defective within the period stated. This remedy is expressly agreed to be exclusive as a condition of sale. No person is authorized to assume for Fellowes any warranty liability, except as expressly set forth in this paragraph, or set forth in writing by an authorized officer of the company.

Any and all labor charge backs must be pre-approved by Fellowes' Customer Service Manager in writing. Fellowes will reimburse authorized Fellowes dealers and service centers with a credit against future orders.

This warranty does not apply to damage resulting from accident, alteration, transport, or misuse, as well as damage from normal wear and tear such as dents, nicks, scratches, fading and improper maintenance. Fellowes employs quality measures to ensure color consistency in our products. However, due to the effects of light and other environmental factors, no guarantee can be made for an exact

match to product in an existing installation.

Fellowes makes no warranty to purchasers who acquire products for personal, family, or household purposes, or to purchasers acquiring the product other than directly from Fellowes, its authorized dealers, or others who are specifically authorized by Fellowes to sell such products. Fellowes' liability with respect to its products shall not exceed that expressly set forth above irrespective of the theory upon which a claim might be based, including negligence. Under no circumstances shall Fellowes be liable for incidental or consequential damages. Original product label must be attached to the product in question.

The warranty period is not interrupted or prolonged by the performance of a service under the terms of the warranty. There are no other warranties except as expressly set forth above, either express or implied, and Fellowes expressly disclaims any warranty of design, merchantability or fitness for any purpose.

This warranty supersedes all previously printed Fellowes warranties.

Governing Law and Dispute Resolution.

In no case shall the 1980 U.N. Convention on Contracts for the International Sale of Goods apply.

If Seller is Fellowes, Inc. or any other subsidiary or joint venture of Fellowes, Inc. not listed below:

The construction, validity and performance of these Terms and Conditions shall be governed and construed according to the internal laws of the State of Illinois. Seller and Customer agree that any legal action arising out of or relating to this agreement or the transactions contemplated by this agreement shall be brought in either the United States District Court in and for the Eastern Division of the Northern District of Illinois or the Circuit Court in and for Du Page County, Illinois, and consents to personal jurisdiction of such courts over them in any such action. Seller and Customer waive any defense of inconvenient forum to the maintenance of any such action or proceeding so brought and waives any bond, surety, or other security that might be required of either Seller and Customer.

If Seller is Fellowes Canada, Ltd.

The construction, validity and performance of these Terms and Conditions shall be governed and construed according to the internal laws of the Province of Ontario, without giving effect to any choice or conflict of law provision or rule that would cause the application of the laws of any jurisdiction other than the Province of Ontario. Each of the Parties agrees that any legal action arising out of or relating to this Agreement shall be brought in Ontario, Canada, and consents to the personal jurisdiction of such courts over the Parties in any such action. Each of the Parties waives any defense of inconvenient forum to the maintenance of any such action or proceeding so brought and waives any bond, surety, or other security that might be required of any Party hereto.

If Seller is Fellowes Ltd, Fellowes Ibérica S.L., Fellowes GmbH, Fellowes Polska S.A., Fellowes RU Ltd, Beswick Office Products (Pty) Ltd., Fellowes Leonardi S.p.A., or Fellowes France SA

The construction, validity and performance of these Terms and Conditions shall be governed and construed according to the laws of England and Wales. Seller and Customer agree that any legal action arising out of or relating to this agreement or the transactions contemplated by this agreement shall be brought in England and Wales, and consents to personal jurisdiction of such courts over them in any such action. Any such action shall be conducted in

English. Seller and Customer waive any defense of inconvenient forum to the maintenance of any such action or proceeding so brought and waives any bond, surety, or other security that might be required of either Seller and Customer.

If Seller is Fellowes (Australia) Pty. Ltd:

The construction, validity and performance of these Terms and Conditions shall be governed and construed according to the laws of Victoria, Australia. Seller and Customer agree that any legal action arising out of or relating to this agreement or the transactions contemplated by this agreement shall be brought in courts of the State of Victoria, and consents to personal jurisdiction of such courts over them in any such action. Any such action shall be conducted in English. Seller and Customer waive any defense of inconvenient forum to the maintenance of any such action or proceeding so brought and waives any bond, surety, or other security that might be required of either Seller and Customer.

If Seller is Fellowes Office Products Suzhou Co. Ltd, Fellowes Singapore, Fellowes Malaysia, Fellowes Korea Ltd:

The construction, validity and performance of these Terms and Conditions shall be governed and construed according to the internal laws of the State of Illinois. Any controversy or claim arising out of or relating to these Terms and Conditions, or the breach thereof, will be determined by arbitration administered by the International Centre for Dispute Resolution ("ICDR") in accordance with its International Arbitration Rules. A request for interim measures addressed by Seller and Customer to a judicial authority will not be deemed incompatible with the agreement to arbitrate or a waiver of the right to arbitrate. The place of arbitration will be Chicago, Illinois, U.S.A. The number of arbitrators shall be three (3); Seller and Customer will each appoint one (1) arbitrator, and ICDR will appoint a third arbitrator, who will be the presiding arbitrator. The language of the arbitration will be English. The arbitration award made by ICDR will be final and binding upon the parties. The costs of arbitration will be borne by the losing party, unless otherwise determined by the arbitration award.

Notwithstanding the forgoing, if Customer is domiciled in the People's Republic of China or any other jurisdiction that does not enforce the judgments from a court of a jurisdiction designated by the foregoing paragraphs, the paragraph calling for arbitration with the ICDR shall apply.

Relationship of parties.

References herein to "Customer" include the person or entity specifically identified in the Invoice as "Customer" and its divisions, subsidiaries and affiliated companies. The relationship of the Parties hereto is that of vendor and purchaser. Nothing in these Terms and Conditions, and no course of dealing between the Parties, shall be construed to create any other type of relationship. Accordingly, Customer shall not be empowered to bind Fellowes in any way, to incur any liability or otherwise act on behalf of Fellowes.

Severability.

If any clause or portion of these Terms and Conditions shall be held by a court of competent jurisdiction to be illegal, invalid, or unenforceable, the remaining clauses or portions shall remain in full force and effect.

Force majeure.

Fellowes shall not be liable hereunder for any failure or delay in the performance of its obligations under these Terms and Conditions,

if such failure or delay is on account of causes beyond its control, including labor disputes, civil commotion, contagion, pandemic, war, fires, floods, inclement weather, governmental regulations or controls, casualty, government authority, strikes, or acts of God, in which event the Fellowes shall be excused from its obligations for the period of the delay and for a reasonable time thereafter. Fellowes shall use reasonable efforts to notify the other Party of the occurrence of such an event within five business days of its occurrence.

Fellowes Customer Service Contacts:

Workspace

Phone: 800-833-3746

Email: ci-mesacustomerservice@fellowes.com

Furniture, Modular Walls, and Air Quality Management

Phone: 800-893-8115

Email: ci-quincycustomerservice@fellowes.com



